

# 560

MODELLI MODELS	MOMENTO LIFTING MOMENT	SBRACCIO ORIZ. HORIZ. HYDRAULIC OUTREACH	PORTATA AL DISTRIBUTORE OIL FLOW TO THE CONTROL VALVE	SBRACCIO MAX. VERTICALE MAX VERTICAL REACH	PESO WEIGHT	PRESSIONE PRESSURE	INTERASSE STABILIZZATORI STANDARD APERTI DISTANCE BETWEEN CENTRES WITH OPENED OUTRIGGERS
	Tm.	m.	l.min	m.	Kg	bar	mm.
560A1	5.90	5.40	18	8.3	777	240	3250
560A2	5.85	7.10	18	9.92	833	240	3250
560A3	5.70	8.75	18	11.55	892	240	3250

Autocarro consigliato - Recommended truck - Camion conseille - Camion aconsejado  
M.T.T. ton 7,5 - G.V.W. ton 7,5

#### STANDARD



#### STANDARD CE

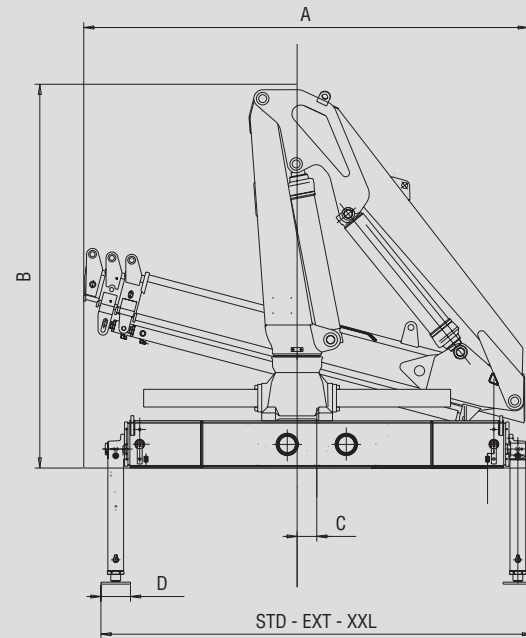
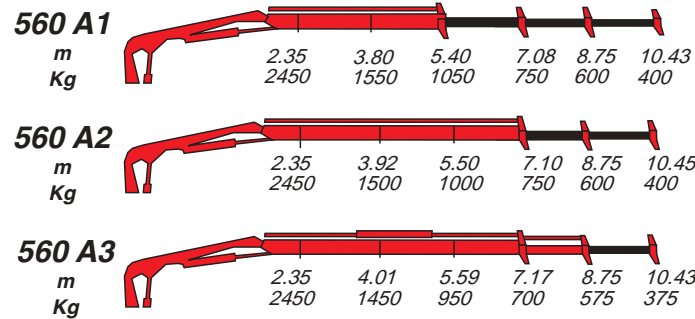

560	A	B	C	STD	EXT	XXL	D
560A1	2140	1950	100	2200	2200	2400	150
560A2	2220	1950	100	2200	2200	2400	150
560A3	2285	1950	100	2200	2200	2400	150

#### SPAZIO RICHiesto PER L'INSTALLAZIONE NECESSARY SPACE FOR INSTALLATION

560	STD	XXL	con attivazioni	STD	XXL
560A1	600	740	With extra function	820	860
560A2	600	740		820	860
560A3	700	835			



F.lli FERRARI CORPORATION S.p.A.

Via Pasubio, 3

42022 Boretto (RE) Italy

Tel. +39 0522/964921

Fax +39 0522/964405

E-mail: [marketing@flliferrari.it](mailto:marketing@flliferrari.it)

M.K.T.5800101 03/04 3000

  
**560**



# 560



F.LLI FERRARI CORPORATION S.p.A.

Dati, descrizioni e illustrazioni sono indicativi e non impegnano F.lli Ferrari. Gru prodotte e/o commercializzate da F.lli Ferrari - Data, descriptions and illustrations are merely indicative and not binding. Cranes manufactured and marketed by F.lli Ferrari - Les données, descriptions et illustrations sont uniquement indicatives et n'engagent pas F.lli Ferrari. Grues produites et/ou vendues par F.lli Ferrari - Angaben, Beschreibungen und Abbildungen sind weisend und verpflichten nicht F.lli Ferrari. Die Kräne werden von F.lli Ferrari hergestellt und/oder vermarktet - Los datos, las descripciones y las ilustraciones son indicativos y no implican compromiso para F.lli Ferrari. Gruas producidas y/o comercializadas por F.lli Ferrari - Os dados as descrições e ilustrações são indicativos e não comprometem F.lli Ferrari. Guindaste produzidos e/ou comercializados pela F.lli Ferrari.

# Ferrari 560



I

La gru F.lli Ferrari mod. 560 racchiude in se caratteristiche tecniche e meccaniche di elevata qualità

- Acciai ad alto limite di snervamento
- Basamento e pignone colonna in fusione
- Struttura interamente sabbiata
- Bracci esagonali
- Sbracci fino a 8.5 m (10.43 con prolunga meccanica)
- Valvole di sicurezza flangiata
- Comandi bilaterali
- Limitatore di momento (CE)
- Stabilizzatori rotanti
- Pattini di scorrimento con ripresa gioco autoserrante
- Boccole autolubrificanti
- Raccorderia SAE J 1514I
- Gancio girevole
- Kit di montaggio compreso

**Accessori**

- Prolunghe meccaniche
- Stabilizzatori extraestendibili (4.196)
- Stabilizzatori superextraestendibili (5.504)
- Stab. estendibili idraulicamente
- Traverse supplementari
- Comandi supplementari attivati (solo A1-A2)
- Verricello idraulico
- Comando a distanza
- Sedile
- Utilizzo con attrezzo
- Dispositivo di controllo RLC

GB

The crane model 560 from F.lli Ferrari has been projected and manufactured with high quality technical and mechanical characteristics

- Steel at high yielding edge
- Basement and column pinion by melding made
- Structure fully sandblasted
- Hexagonal booms
- Hydraulic outreach until 8.75 mt (10.43 with mechanical boom)
- Flanged valves
- Bilateral controls
- Load limiting device (CE)
- Turning outriggers
- Sliding pad with self-adjusting gap
- Self-tapping bushings
- SAE JIC 1514I fittings
- Turning hook
- Mounting kit included

**Accessories**

- Mechanical booms
- Extra wide outriggers (4.196)
- Super-extra wide outriggers (5.504)
- Hydraulic opening cylinders
- Extra beams
- Extra functions (A1 - A2)
- Hydraulic winch
- Remote control
- Top seat
- Use with special equipments
- Load radio checking device RLC

F

LA grue modèle 560 F.lli Ferrari est conçue avec des caractéristiques techniques et mécaniques de plus haute qualité

- Acier à haut niveau de déformation plastique
- Embase et pignon colonne moulés
- Structure complètement sablée
- Rallonges hexagonales
- Portée Hydraulique jusqu'à 8.75 Mt (10.43 mt avec rallonges mécaniques)
- Vannes bridées
- Commandes bilatérales
- Limiteur de moment (CE)
- Béquilles tournantes
- Patins de coulissement auto enregistrables
- Douilles autolubrifiantes
- Raccords SAE-JIC 1514I
- Crochet tournant
- Kit de montage inclus

**Accessoires**

- Rallonges mécaniques
- Béquilles extra larges (4.196)
- Béquilles super extra larges (5.504)
- Béquilles à ouverture hydraulique
- Poutres bâquilles supplémentaires
- Circuits supplémentaires activées (A1 - A2)
- Treuil hydraulique
- Commande à distance
- Siège en haut
- Utilisation avec accessoires
- Dispositif de contrôle de la charge RLC

D

Das Kranmodell 560 vom F.lli Ferrari ist mit höchsten Qualität für technischen und mechanischen Eigenschaften projiziert und hergestellt worden

- Stahl am hohen einträglichen Rand
- Sockel und Zahnrad beim Schmelzen gemacht
- Struktur voll Sand gestrahlt
- Sechseckige Ausschuße
- Hydraulischen Reichweiten bis 8.75 mt. (10.43 mt mit mechanischen Ausschube)
- Geflanscht Ventilen
- Zweiseitige Kontrollen
- Lasthaltventil (CE)
- Drehbar Abstützungen
- Gleitschuh mit Selbstnachsteller Spiel
- Selbstschmierende Buchsen
- SAE-JIC 1514I Anschlusse
- Schwenkbar Haken
- Einsatzbau eingeschlossen

**Zubehöre**

- Mechanische Ausschube
- Extra-weit Abstützungen (4.196)
- Super Extra-weit Abstützungen (5.504)
- Abstützungen mit hydraulischen Öffnung
- Zusatzabstützungen
- Zusatzfunktionen (A1 - A2)
- Hydraulischer Winde
- Fernsteuerung
- Hochsitz
- Benutzung mit Zubehöre
- Gewichtskontrolle Vorrichtung RLC

SP

El modelo de la grúa 560 de F.lli Ferrari se ha proyectado y fabricado con características técnicas y mecánicas de alta calidad

- Acero en el alto borde de rendimiento
- Piñón de la columna y basamento moldeados
- Estructura completamente arenada
- Prolongas hexagonales
- Alcances hidráulicos hasta mt. 8.75 (10.43 mt con prolongas mecanicas)
- Valvulas rebordeadas
- Mandos bilaterales
- Limitador de momento (CE)
- Patas giratorias
- Patin de deslizamiento con juego autoregurable
- Casquillos autolubrificantes
- Empalmes SAE-JIC 1514I
- Gancho giratorio
- Kit de montaje incluido

**Accesorios**

- Prolongas mecanicas
- Patas extra-largas (4.196)
- Patas super extra-largas (5.504)
- Patas con abertura hidraulica
- Patas adicionales
- Activaciones adicionales (A1 - A2)
- Cabrestante hidraulico
- Mando a distancia
- Puesto de mando arriba
- Utilización con accesorios
- Dispositivo de verificación de carga RLC

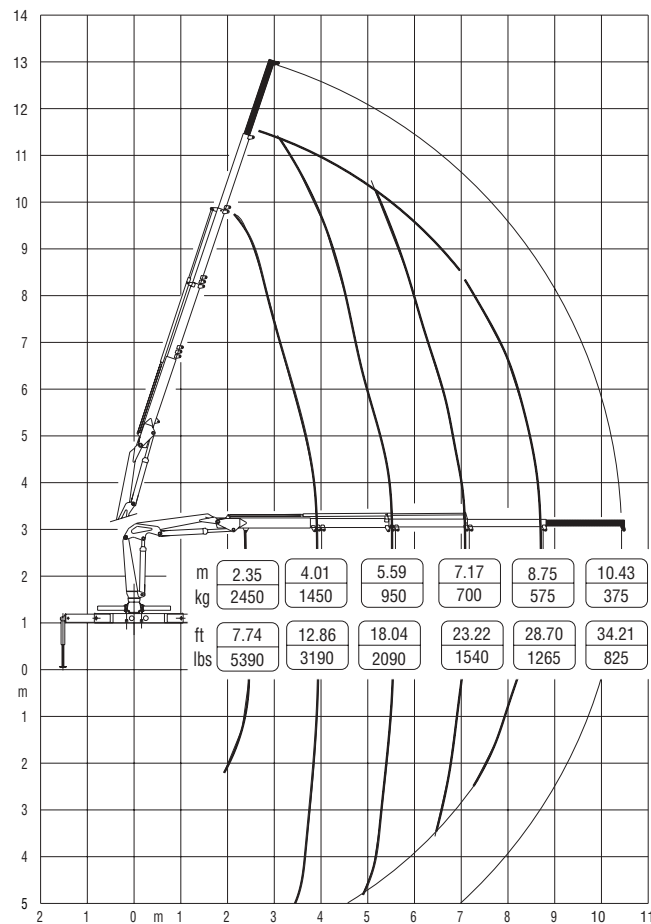

Questo dispositivo visualizza su un display collocato in prossimità dei comandi il carico applicato al gancio della gru, rendendo l'utilizzo delle prolunghe meccaniche sicuro secondo la normativa europea EN 12999.

This device shows the load at the hook on a display placed near the controls, making safe the use of the mechanical booms following the European rule EN 12999.

