



GO THE DISTANCE.

FIFTH WHEELS CATALOG & SELECTION GUIDE



**STATIONARY
SLIDING
KOMPENSATOR®**

**OSCILLATING
LIGHT COMMERCIAL**

**RIGID
NO-TILT
ELEVATING
YARD SPOTTER
ILS® SLIDER**

www.thehollandgroupinc.com

2007

TECHNOLOGY

advanced technology delivers superior performance



Holland fifth wheels have earned a reputation for exceptional durability, driver productivity and reliability that continues to “raise the bar” on fifth wheel performance standards while lowering the total cost-of-ownership.

Revolutionary Designs

The Holland 3500 model fifth wheel has been the foundation for evolutionary new ideas that expand fifth wheel function and value. For example, Holland’s 3500 NoLube model eliminates all fifth wheel lubrication requirements. This advancement means that drivers no longer get dirty from greasy fifth wheels. Nor do they spend time greasing top plates or locks. Shop managers can improve the work environment for mechanics and reduce the potential for costly injuries from slips and falls on greasy floors. And, fleets can protect the environment from excess grease on the road or in our water supply.

Other Holland innovations on the 3500 Series include a system for in-cab air release of the fifth wheel locks, an Electronic Lock Indicator (ELI) which insures a secure coupling between tractor and trailer, and the new ILS® low weight, integrated sliding fifth wheel bracket.

Guaranteed Performance

Holland has raised the bar on supplier accountability. We offer the industries first fifth wheel “wear-out” guarantee. We call it our *Performance Guarantee*. Basically, we guarantee that your Holland fifth wheel will perform according to our operating instructions or we will take care of the cost to repair or replace it. Please see the appropriate fifth wheel warranty statement for further information.

Innovative Holland fifth wheel technology is the best in the world. Our fifth wheels offer proven value and performance in addition to exceptional operating and economic advantages.





TABLE OF CONTENTS

FIFTH WHEEL CATALOG & SELECTION GUIDE

How to Use this Guide 3

Items to Consider Before Selecting Your Fifth Wheel

Fifth Wheel Types (Stationary/Slider) 4
 Fifth Wheel Ratings, Capacities, Heights, Weights and Cost 5

Fifth Wheel Applications

Applications (By Fifth Wheel Type) 6 - 7

Features of Holland Fifth Wheels

Top Plate Assemblies

3500 (FW35) XA-351 Series 8
 FW17 XA-17 Series 9
 3500 NoLube (FW31) XA-311 Series 10
 3500 LowLube (FW33) XA-331 Series 11
 FleetMaster (FW8) XA-201 Series 12
 FleetMaster LowLube (FW83) XA-231 Series 13
 Extra Capacity (FW0070) XA-71 Series 14
 Stationary Mount Brackets 15
 Slide Bracket and Plate Assemblies 16

Heavy Duty Stationary Fifth Wheels

CAPACITY

	Max. Vertical Load Pounds	Max. Drawbar Load Pounds	
FW0100 Series	100,000	200,000	17
FW0165 Series	165,000	200,000	17

Stationary Kompensator® Fifth Wheels

FW8 Series 50,000 150,000 18
 FW35 Series (3500) 55,000 150,000 18
 FW7040 Series 70,000 200,000 19

Oscillating Fifth Wheels

FW1560-B 40,000 150,000 20
 FW2080 Series 70,000 200,000 20

Yard Spotter Fifth Wheels

FW35-03344 Series 70,000 21
 FW2870-03184 Series 100,000 21
 FW1560-C 50,000 22

Special Features Fifth Wheels

FW1226 Rigid Type 40,000 150,000 22
 “No-Tilt” Convertible Depends upon fifth wheel selection 23
 “No-Tilt” Mounting Systems 24

Continued on next page

TABLE OF CONTENTS



Mov-On Elevating Fifth Wheels

Air Lifts	Lift Capacity	
FW6700-16B	40,000	25
Hydraulic Lifts	Lift Capacity	
FW2800-X	50,000	25
FW2900-X	50,000	25
FW2800-5X	100,000	25
FW2900-5X	100,000	25

Light Commercial Fifth Wheels

	CAPACITY		
	Max. Vertical	Max. Drawbar	
	Load Pounds	Load Pounds	
FW1900 Series	20,000	40,000	26
FW6000 Series	12,000	32,000	27
FW0001 Series	8,000	23,000	27
Accessories for FW1900 and FW6000 Series Fifth Wheels			28

Air Release Systems

Fifth Wheel Lock Release System	29
---------------------------------------	----

Application Limitations

Selection Tables

Fifth Wheels for Power Units (Tractors)

A. Van Trailers	31
B. Tanker and Dry Bulk Trailers	32
C. Flatbed, Stretch, and Pole Trailers	33
D. End Dump (Framed) Trailers	34
E. End Dump (Frameless) Trailers	35
F. Side Dump Trailers	36
G. Bottom Dump Trailers	37
H. Lowboy Trailers	38
Fifth Wheels for Converter Dollies	39

Fifth Wheels for B-Trains

A. Van, Flatbed and Stretch Trailers	40
B. Tanker and Bottom Dump Trailers	40
C. End Dump Trailers	41
Fifth Wheels for Light Commercial Trailers	41

Popular Options for Fifth Wheels

Custom Service Tools for Fifth Wheels

Fifth Wheel Location and Installation

Glossary

HOW TO USE THIS GUIDE

The Holland Fifth Wheel Selection Guide is set up to help you quickly complete the fifth wheel selection process. Simply complete Steps 1 through 7 below, and you will be well on your way to placing an order for the correct fifth wheel for your vehicle.

Step 1

Review “*Items to Consider Before Selecting Your Fifth Wheel*” Section: Stationary/Sliding, Ratings and Capacities, Height, Weight, Cost.

Step 2

Determine the type of vehicle your fifth wheel will be mounted on (for example, tractor, converter dolly, or B-train connection) and the type of trailer your fifth wheel will be connected to (for example, van, tanker, etc.).

Step 3

Use the table on Page 31 to determine whether your vehicle will be used in a **Standard, Moderate** or **Severe** Duty application.

Step 4

Locate your *vehicle* and *trailer type* in the “Selection Tables” section of the Table of Contents, and turn to the appropriate fifth wheel selection page (for example, fifth wheels for *tractors* pulling *dry bulk trailers* are found on Page 31).

Step 5

Refer to the appropriate application as determined in Step 3 and using the vehicle descriptions and expected capacity requirements, review the series and types of fifth wheels recommended.

Step 6

After selecting the fifth wheel type that meets your requirements, refer to your Holland fifth wheel sales literature for specific part number and ordering information. This literature is available from any Holland distributor or dealer or directly from Holland.

Step 7

If there is still insufficient information on which to make a selection, contact your Holland representative for assistance. In the U.S., call 1-888-396-6501. In Canada, call 519-537-2366. For a complete listing of all Holland USA and Holland Canada facilities, see the back cover of this guide.

ITEMS TO CONSIDER BEFORE SELECTING YOUR FIFTH WHEEL

In addition to selecting the proper fifth wheel model for your application, the following additional items must be considered before you specify your complete fifth wheel assembly:

Stationary or Sliding

Stationary

Stationary fifth wheels are best suited for applications where the **1)** axle loading, **2)** kingpin setting, and **3)** vehicle combination length all remain constant throughout the fleet. Stationary fifth wheels are generally lighter weight and lower in cost than sliding fifth wheels; however, they do not offer the application flexibility of a sliding fifth wheel.

If a stationary fifth wheel is chosen, the user still must determine whether to use an “angle-on-frame” (low cost and less torsional rigidity, see **Figure 1**), a “plate mount” (higher cost and high torsional rigidity, see **Figure 2**) or an “outboard angle mount” (universal hole pattern for medium torsional rigidity bolt-on mounting, see **Figure 3**). This selection should be made to compliment the suspension and tractor frame.

Sliding

The selection of a sliding fifth wheel (see **Figures 4 - 6**) provides the capability to **1)** transfer weight between tractor axles, **2)** accommodate trailers with different kingpin settings and, **3)** vary vehicle combination lengths. A sliding fifth wheel also provides the following additional benefits:

Resale: A sliding fifth wheel offers maximum equipment flexibility and is more likely to fit the application of a prospective purchaser.

Improved Maneuverability: A sliding fifth wheel positioned forward provides additional maneuverability in tight locations and sliding the fifth wheel rearward accommodates trailers with short landing gear clearance.

Ride Comfort: Driver comfort is increased as the fifth wheel is located closer to the centerline of the bogie or rear axle. When the axles are not overloaded, the driver has the ability to extend the unit for maximum comfort.

If a sliding fifth wheel is chosen, the mounting style (“outboard angle” “inboard angle” or “direct mount”) (see **Figures 4 - 6**) and slide length must be specified:

Slide Length: Proper slide length specification is very important. If the slide length is too short, optimum equipment utilization may not be achieved (i.e. inability to shift enough kingpin load to the front axle). However, if too long a slide length is specified, either overloading of the front axle or interference between the tractor/trailer may occur during cornering. A slide length which is too long also results in additional tractor weight and fifth wheel initial cost.

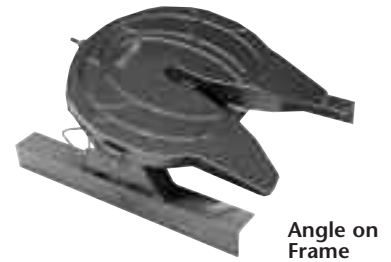

Figure 1

Angle on Frame



Figure 2

Plate Mount

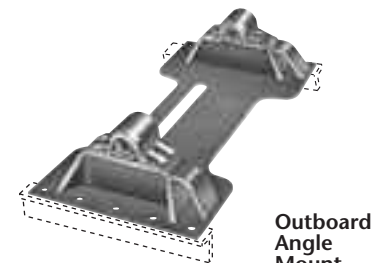

Figure 3

Outboard Angle Mount



Figure 4

Outboard Angle Mount



Figure 5

Inboard Angle Mount



Figure 6

Direct Mount

ITEMS TO CONSIDER BEFORE SELECTING YOUR FIFTH WHEEL

Fifth Wheel Ratings and Capacities

The selection of the proper fifth wheel capacity is a major consideration. The use of a fifth wheel that does not meet the required capacity and the demands of the application may result in an unsafe operating condition and maintenance problems. The user should specify a higher capacity rating than his normal needs require, taking into consideration the towed vehicle weight (TVW) to be pulled, maximum drawbar load expected, vertical load to be carried by the fifth wheel and type of operation. Off-highway use will normally require a higher capacity rating. For example, a tractor pulling a 130,000 GTW trailer, with a 50,000 lbs. vertical load for off-road use, should be specifying a HOLLAND extra capacity, stationary mount FW0070 fifth wheel which has a drawbar capacity of 200,000 lbs. and a vertical load capacity of 70,000 lbs.

Fifth Wheel Height

Another item to specify while selecting a fifth wheel is the fifth wheel height. This is a critical specification because the overall combination height cannot exceed 13' 6". The fifth wheel is designed to operate with the top plate level, so every attempt should be made to match the fifth wheel height with the trailer upper coupler (bolster plate) height.

An important consideration relative to fifth wheel height is developing a standard fleet specification. Having all tractors with the same mounted fifth wheel height (height from the ground to the top of the fifth wheel) will reduce the need to adjust the trailer landing gear before coupling and consequently aid in proper coupling.

The maximum allowable fifth wheel height is determined by subtracting the trailer height and tractor frame height from the maximum height of 13' 6". As a final check, the tire clearance should be considered, keeping in mind spring deflection under full load.

Note: The lower the fifth wheel height, the less articulation available, especially in off-road applications. Operating conditions must be considered to ensure the tractor-trailer will not exceed the available articulation, resulting in damage to the fifth wheel, tractor frame or trailer.

Fifth Wheel Weight

The weight of the fifth wheel should be a balance between operational cost, strength, and durability. Any additional weight (above the requirements of your operation) will result in additional expense. This expense will be in initial cost, reduced cargo carrying capacity, and additional fuel cost.

Purchasing the lightest fifth wheel, however, may not result in the lowest cost. Lighter weight may be a trade-off of strength and durability and can result in additional maintenance, downtime, and expense.

Cost

No discussion of fifth wheels is complete without referring to costs. The user should always balance the cost of the unit to be purchased against the job required, maintenance costs, wear life, and availability of parts and service. The purchase of an inexpensive fifth wheel may result in additional operational and repair costs related to downtime and potential kingpin replacement and tractor or trailer frame damage which can far exceed the initial cost of a premium fifth wheel.

If a specialty fifth wheel (e.g. a Kompensator®) or special options have been recommended for your application, special consideration should be given to those recommendations. The benefits received may offset the additional initial cost.

Also, if your vehicle is expected to serve in multiple applications, a fifth wheel that will adequately perform all functions should be chosen.

FIFTH WHEEL APPLICATIONS

Semi-Oscillating Type

The standard over-the-road fifth wheel is the semi-oscillating type (See **Figure 1**) which oscillates or articulates about an axis perpendicular to the vehicle centerline to accommodate for normal road variations (inclines, bumps, etc.)

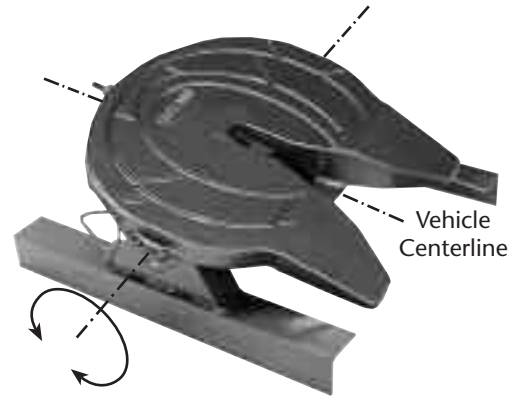

Figure 1
Top Plate, Brackets & Lock Grease Required

NoLube

An over-the-road semi-oscillating fifth wheel (See **Figure 2**) model designed to completely eliminate all lubrication requirements. Patented surface alloy on the kingpin contact surfaces of the lock jaws provide lubrication-free operation, eliminating the need to grease the locks. Molded “lube free” inserts in the top plate and “lube free” pocket inserts also eliminate the need for lubrication.



Figure 2
NoLube – No Greasing Required

LowLube

An over-the-road semi-oscillating fifth wheel (See **Figure 3**) designed to eliminate the use of grease on the top plate and between top plate and bracket. Grease is supplied to the lock jaws through an easily accessed lube fitting near the release handle. Routine maintenance and lubrication of the locking mechanism is still required. Molded “lube free” inserts in the top plate and “lube free” pocket inserts eliminate the need for lubrication in these areas.



Figure 3
LowLube – Requires Only Lock Greasing

Fully (Double) Oscillating Fifth Wheel

A fifth wheel designed to provide both front-to-rear and side-to-side oscillation between the tractor and semi-trailer; for vehicles that operate on rough and uneven terrain (mining, logging, etc.) (See **Figure 4**). The oscillation is provided by the use of an undercarriage employing both transverse and longitudinal shafts. The side-to-side oscillation pivot point is located below the fifth wheel bearing surface. ***It is intended for applications where the center of gravity of the loaded semi-trailer is at or below the top of the fifth wheel.***

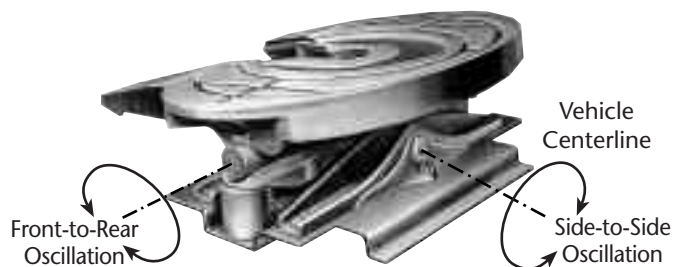

Figure 4

FIFTH WHEEL APPLICATIONS

Rigid Type or “No-Tilt”

A rigid fifth wheel does not oscillate about either axis of the vehicle but is fixed in location (*Figure 5*). In applications which require this type of fifth wheel, the oscillation (articulation) is provided by other means (i.e. articulating upper coupler). The no-tilt convertible (*Figure 6*) can be converted from a rigid or “no-tilt” configuration to a standard semi-oscillating configuration for fleets with mixed trailers and needs for both types.



Figure 5
Rigid Type

Kompensator® Type

This fifth wheel is designed to provide both front-to-rear and side-to-side oscillation between the tractor and semi-trailer (See *Figure 7*). The Kompensator fifth wheel relieves the twisting force between the tractor and trailer. This configuration has its effective side-to-side oscillation pivot point located well above the fifth wheel bearing surface (See *Figure 8*). It is intended for applications where the center of gravity of the loaded semi-trailer does not exceed 44” above the top surface of the fifth wheel. Benefits include improved tire life and a reduction in tractor, trailer, and tank cracks. Ideal applications include rigid trailers (tanker, etc.) operated on uneven and rough terrain.



Figure 6
No-Tilt Convertible



Figure 7
Kompensator

Mov-On® Type (Elevating Fifth Wheels)

This fifth wheel is designed to convert a standard road tractor for low cost, efficient yard spotting, switching and hauling. These fifth wheels are available in air (*Figure 9*) or hydraulic (*Figure 10*) lift.

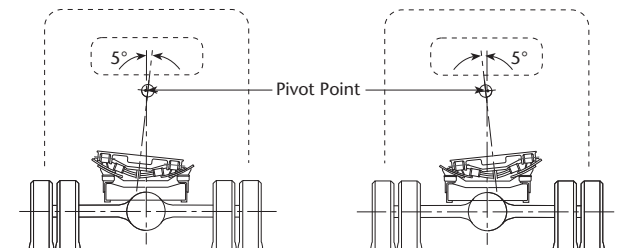

Figure 8



Figure 9



Figure 10

FIFTH WHEEL TOP PLATE MODELS

3500 (FW35) XA-351 Series

Capacity:

55,000 lbs. Maximum Vertical Load
150,000 lbs. Maximum Drawbar Pull

Models Available:

Stationary Kompensator®
Sliding No-Tilt

Warranty:

- Materials and workmanship: 6 years or 600,000 miles
 - Performance Guarantee: 6 years or 600,000 miles
- See 3500 Series Fifth Wheel North American Commercial Warranty for details

Machined top plate to yoke fit-up area maximizes surface contact for extended service life.

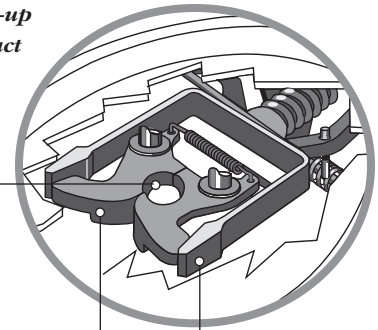

One step rear lock provides high coupling protection.

Forged steel split lock style. Rear lock is machined and heat treated. Provides greater lock and lock pin durability.

Induction hardened solid tip yoke is machined for extended service life.

Infinite lock adjustment positions provide improved lock and kingpin durability.

Lock adjustment nut is readily accessible providing ease of maintenance.

Bracket pin design allows for easy top plate removal and installation, reducing maintenance time.

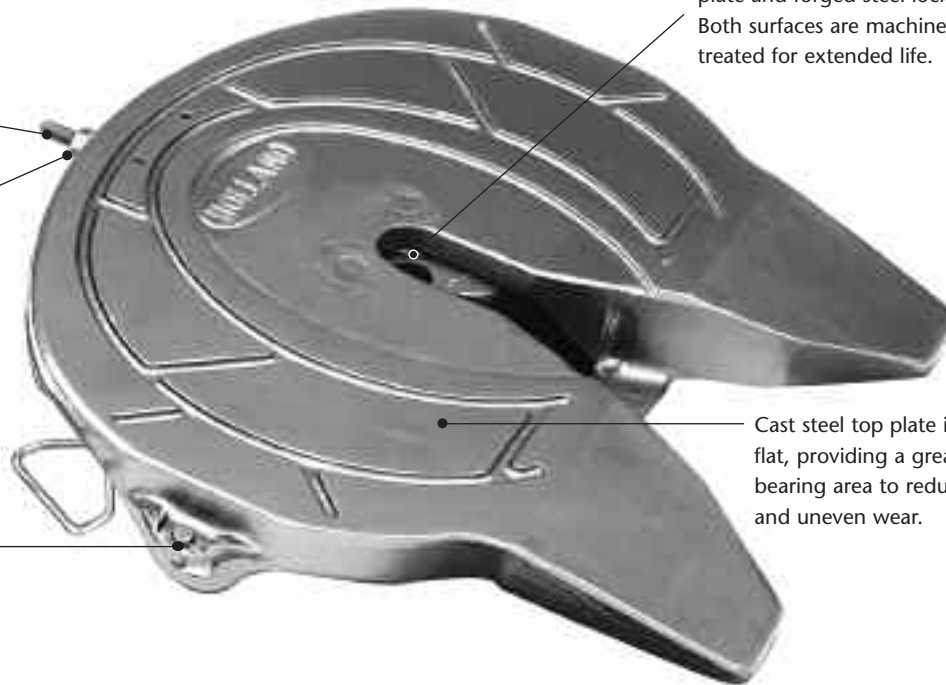

Front lock combines cast steel top plate and forged steel lock design. Both surfaces are machined and heat treated for extended life.

Cast steel top plate is machined flat, providing a greater load bearing area to reduce friction and uneven wear.



Drop release handle requires minimum effort and protects from damage during a missed couple. Available in left or right hand release.

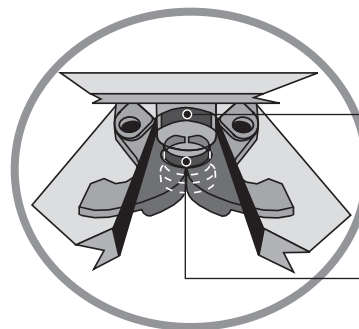

Lock provides 7.46 sq. in. kingpin contact area.

Front lock contact area (3.725 sq in)

Rear lock contact area (3.730 sq in)

TOP PLATES

FIFTH WHEEL TOP PLATE MODELS

FW17 XA-17 Series

Capacity:

50,000 lbs. Maximum Vertical Load
150,000 lbs. Maximum Drawbar Pull

Models Available:

Stationary
Sliding

Warranty:

- Materials and workmanship: 5 years or 500,000 miles
 - Performance Guarantee: 5 years or 500,000 miles
- See FW17 Fifth Wheel North American Commercial Warranty for details*

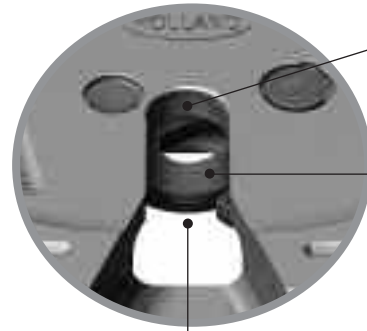

High coupling lock system protects against coupling at an improper height.

Rear lock is forged, hardened and machined steel. Front lock is machined, hardened cast steel.

Greater kingpin contact area (up to 87% more). Provides longer kingpin and lock life.

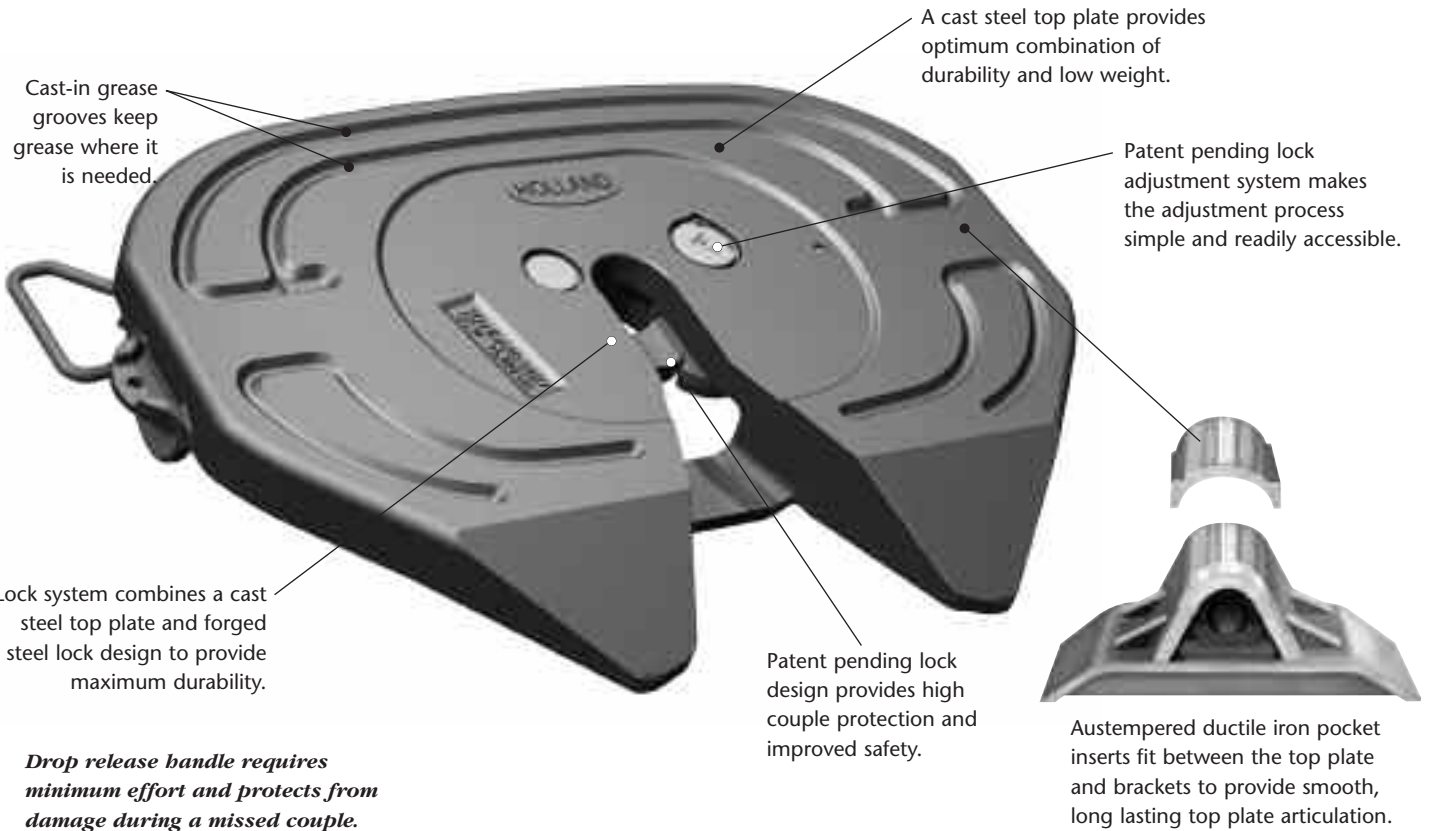

Cast-in grease grooves keep grease where it is needed.

A cast steel top plate provides optimum combination of durability and low weight.

Patent pending lock adjustment system makes the adjustment process simple and readily accessible.

Lock system combines a cast steel top plate and forged steel lock design to provide maximum durability.

Patent pending lock design provides high couple protection and improved safety.

Austempered ductile iron pocket inserts fit between the top plate and brackets to provide smooth, long lasting top plate articulation.

Drop release handle requires minimum effort and protects from damage during a missed couple.



Patent pending release mechanism utilizes lever arm design to minimize pull effort required.

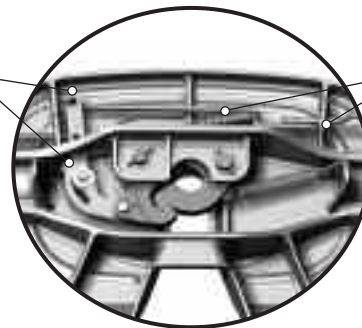

Patent pending release mechanism provides automatic secondary lock to ensure safe operation.

FIFTH WHEEL TOP PLATE MODELS

3500 NoLube (FW31) XA-311 Series

Holland has pioneered the application of advanced coating technologies in the development of our NoLube fifth wheel product line. After exhaustive investigation, we have selected coating technologies that combine low friction, long wear life, and corrosion resistance.

Capacity:

55,000 lbs. Maximum Vertical Load
150,000 lbs. Maximum Drawbar Pull

Models Available:

Stationary Sliding Kompensator®

Warranty:

- Materials and workmanship: 6 years or 600,000 miles
- Performance Guarantee: 6 years or 600,000 miles
- Lube Plates: 2 years or 200,000 miles

See 3500 NoLube Fifth Wheel North American Commercial Warranty for details

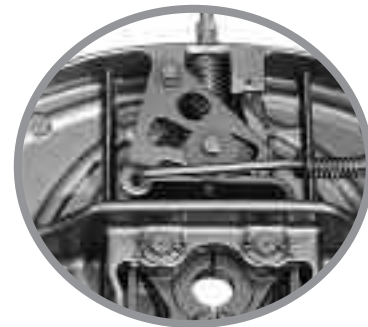

Lock system components are protected with a low friction coating which provides long wear life and corrosion protection.

Infinite lock adjustment positions provide improved lock and kingpin durability.

Lock adjustment nut is readily accessible providing ease of maintenance.

Coated for superior corrosion resistance, the drop release handle requires minimum effort and protects from damage during a missed couple. Available in left or right hand release.

Bracket pin design allows for easy top plate removal and installation, reducing maintenance time.



The replaceable lube plate inserts are mechanically-bound to a unique "perforated" plate that provides friction-free performance and extends the life of the lube plate compound. The lube plates fit into cast recesses of the top plate and are secured by studs and locknuts.

Pocket inserts fit between the top plate and brackets to provide long lasting top plate articulation.



Patented surface alloy on the kingpin contact surfaces of the lock jaws provides lubrication-free operation along with corrosion and wear resistance.



TOP PLATES

FIFTH WHEEL TOP PLATE MODELS

3500 LowLube (FW33) XA-331 Series

Capacity:

55,000 lbs. Maximum Vertical Load
150,000 lbs. Maximum Drawbar Pull

Models Available:

Stationary Kompensator®
Sliding

Warranty:

- Materials and workmanship: 6 years or 600,000 miles
 - Performance Guarantee: 6 years or 600,000 miles
 - Lube Plates: 2 years or 200,000 miles
- See 3500 LowLube Fifth Wheel North American Commercial Warranty for details

Machined top plate to yoke fit-up area maximizes surface contact for extended service life.

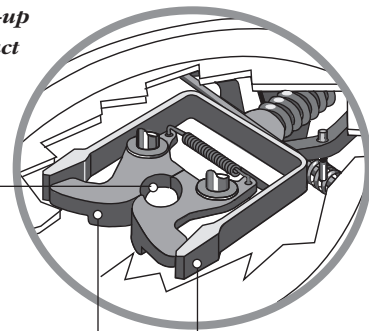

One step rear lock provides high coupling protection.

Forged steel split lock style. Rear lock is machined and heat treated. Provides greater lock and lock pin durability.

Induction hardened solid tip yoke is machined for extended service life.

Infinite lock adjustment positions provide improved lock and kingpin durability.

Lock adjustment nut is readily accessible providing ease of maintenance.

The innovative, replaceable patented lube plate inserts are made of non-abrasive material and molded to a steel backing plate for greater durability. They fit into cast recesses of the top plate and are secured by studs and locknuts.

Drop release handle requires minimum effort and protects from damage during a missed couple. Available in left or right hand release.

Grease fitting and tube provides easy lubrication of locks.



Front lock combines cast steel top plate and forged steel lock design. Both surfaces are machined and heat-treated for extended life.

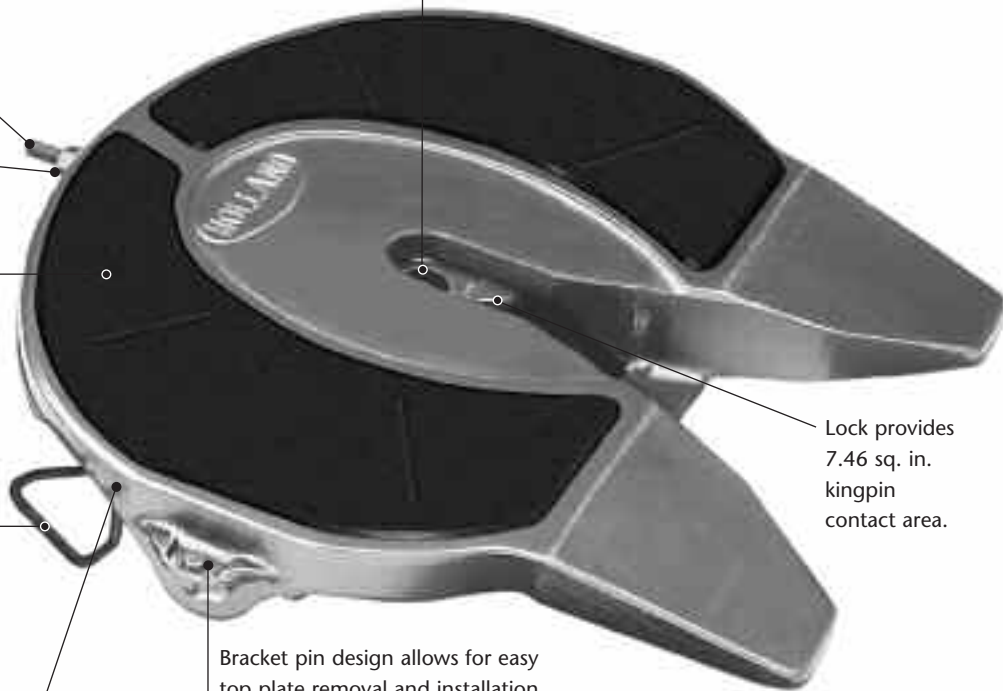

Lock provides 7.46 sq. in. kingpin contact area.

Bracket pin design allows for easy top plate removal and installation, reducing maintenance time.

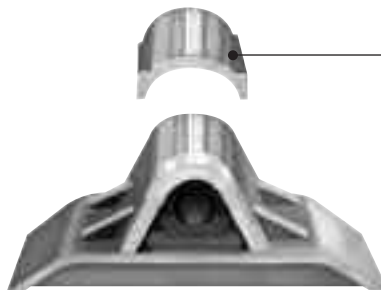

Austempered ductile iron pocket inserts fit between the top plate and brackets to provide smooth, long lasting top plate articulation.

FIFTH WHEEL TOP PLATE MODELS

FleetMaster (FW8) XA-201 Series

Capacity:

50,000 lbs. Maximum Vertical Load
150,000 lbs. Maximum Drawbar Pull

Models Available:

Stationary Kompensator®
Sliding

Warranty:

- Materials and workmanship: 5 years or 500,000 miles
 - Performance Guarantee: 5 years or 500,000 miles
- See FleetMaster Fifth Wheel North American Commercial Warranty for details*

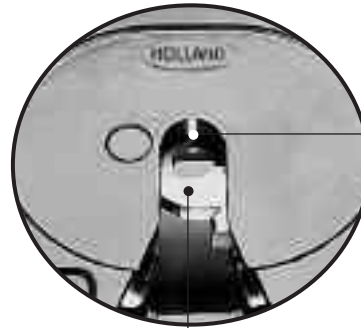

Forged steel, machined and heat treated rear lock with heat treated cast steel front lock. Lock hardness is 321-388 BHN.

Greater kingpin contact area (7.2 sq. in.). Provides longer kingpin and lock life.

Cast in grease grooves.

Cast steel top plate machined flat. Provides greater load bearing area. Reduces friction and uneven wear.

Drop release handle requires minimum effort and protects from damage during a missed couple. Available in left or right hand release.

Easy to remove top plate incorporates new easier to remove bracket pin.

Lightest weight fifth wheel in the industry. Top plate weighs only 217 lbs.

Easily accessible lock adjustment is infinitely adjustable throughout the fifth wheels life.

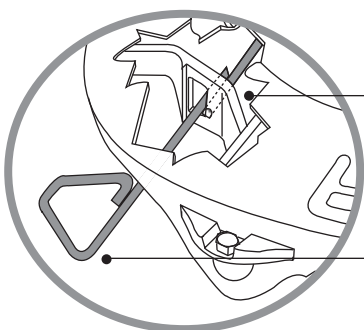

Lock notch behind rib

Release handle also serves as a visual lock indicator.



Drop handle configuration is standard. Reduces handle damage due to improper coupling.

TOP PLATES

FIFTH WHEEL TOP PLATE MODELS

FleetMaster LowLube (FW83) XA-231 Series

Capacity:

50,000 lbs. Maximum Vertical Load
150,000 lbs. Maximum Drawbar Pull

Models Available:

Stationary Kompensator®
Sliding

Warranty:

- Materials and workmanship: 5 years or 500,000 miles
- Performance Guarantee: 5 years or 500,000 miles
- Lube Plates: 2 years or 200,000 miles

See FleetMaster LowLube Fifth Wheel North American Commercial Warranty for details



Forged steel, machined and heat treated rear lock with heat treated cast steel front lock. Lock hardness is 321-388 BHN.

Greater kingpin contact area (7.2 sq. in.). Provides longer kingpin and lock life.

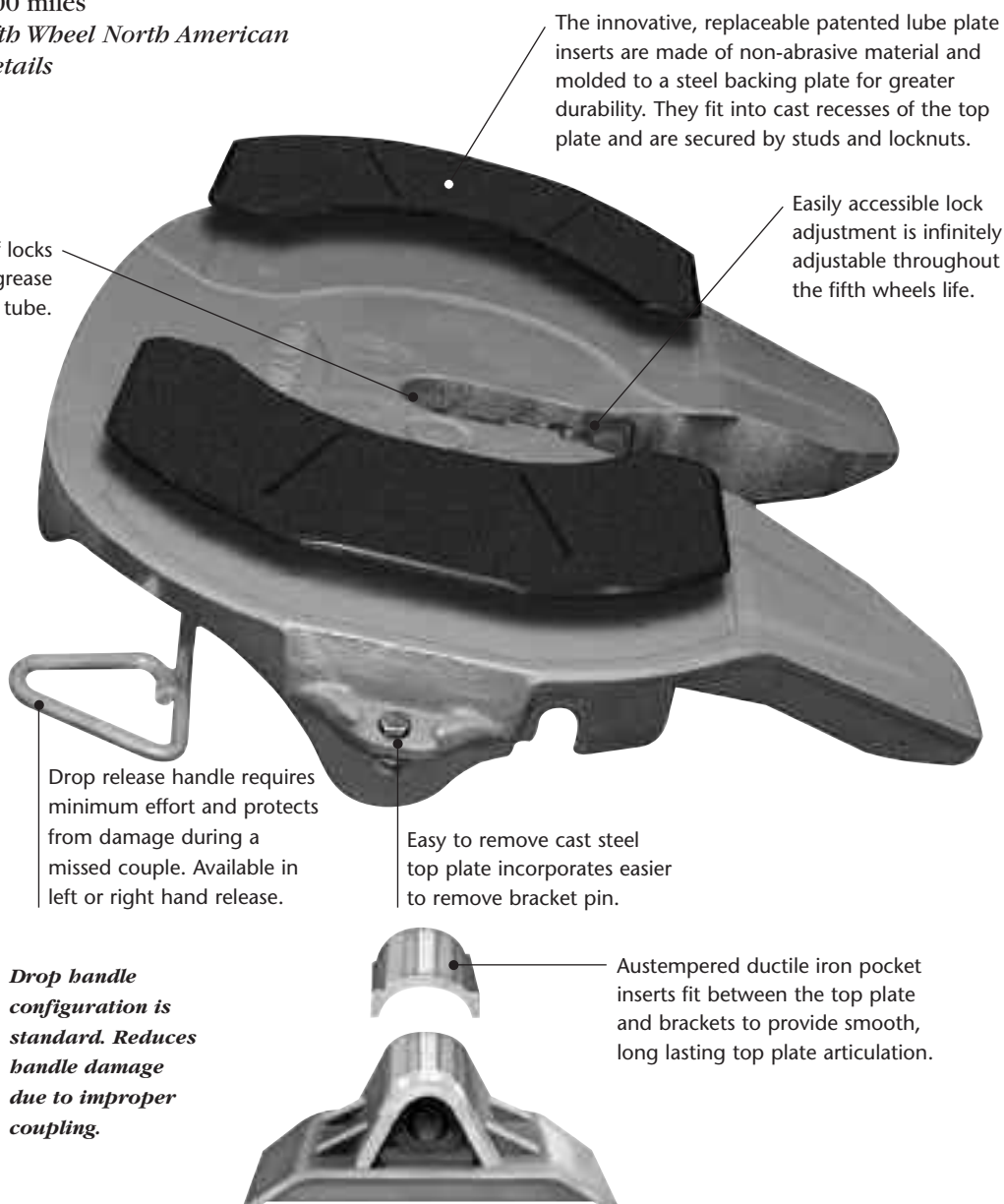

The innovative, replaceable patented lube plate inserts are made of non-abrasive material and molded to a steel backing plate for greater durability. They fit into cast recesses of the top plate and are secured by studs and locknuts.

Easily accessible lock adjustment is infinitely adjustable throughout the fifth wheels life.

Easy lubrication of locks provided by grease fitting and tube.

Lock notch behind rib

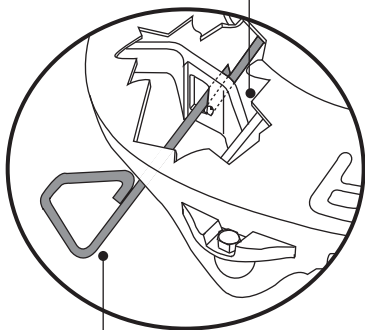

Release handle also serves as a visual lock indicator.

Drop release handle requires minimum effort and protects from damage during a missed couple. Available in left or right hand release.

Easy to remove cast steel top plate incorporates easier to remove bracket pin.

Drop handle configuration is standard. Reduces handle damage due to improper coupling.

Austempered ductile iron pocket inserts fit between the top plate and brackets to provide smooth, long lasting top plate articulation.



FIFTH WHEEL TOP PLATE MODELS

Extra Capacity (FW0070) XA-71 Series

Capacities:

FW2555 Sliding Series

62,500 lbs. Maximum Vertical Load
150,000 lbs. Maximum Drawbar Pull

FW2570 Sliding Series

70,000 lbs. Maximum Vertical Load
150,000 lbs. Maximum Drawbar Pull

FW0070 Stationary Series

70,000 lbs. Maximum Vertical Load
200,000 lbs. Maximum Drawbar Pull

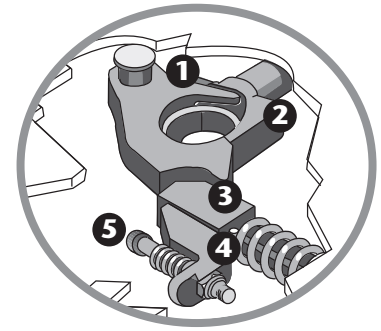

TYPE "A" LOCKING SYSTEM

- 1 Swinging Lock
- 2 Front Lock
- 3 Plunger
- 4 Adjusting Wedge
- 5 Plunger

Locks require only
300 lbs. to couple.
Available for 2" or
3.5" SAE kingpins.

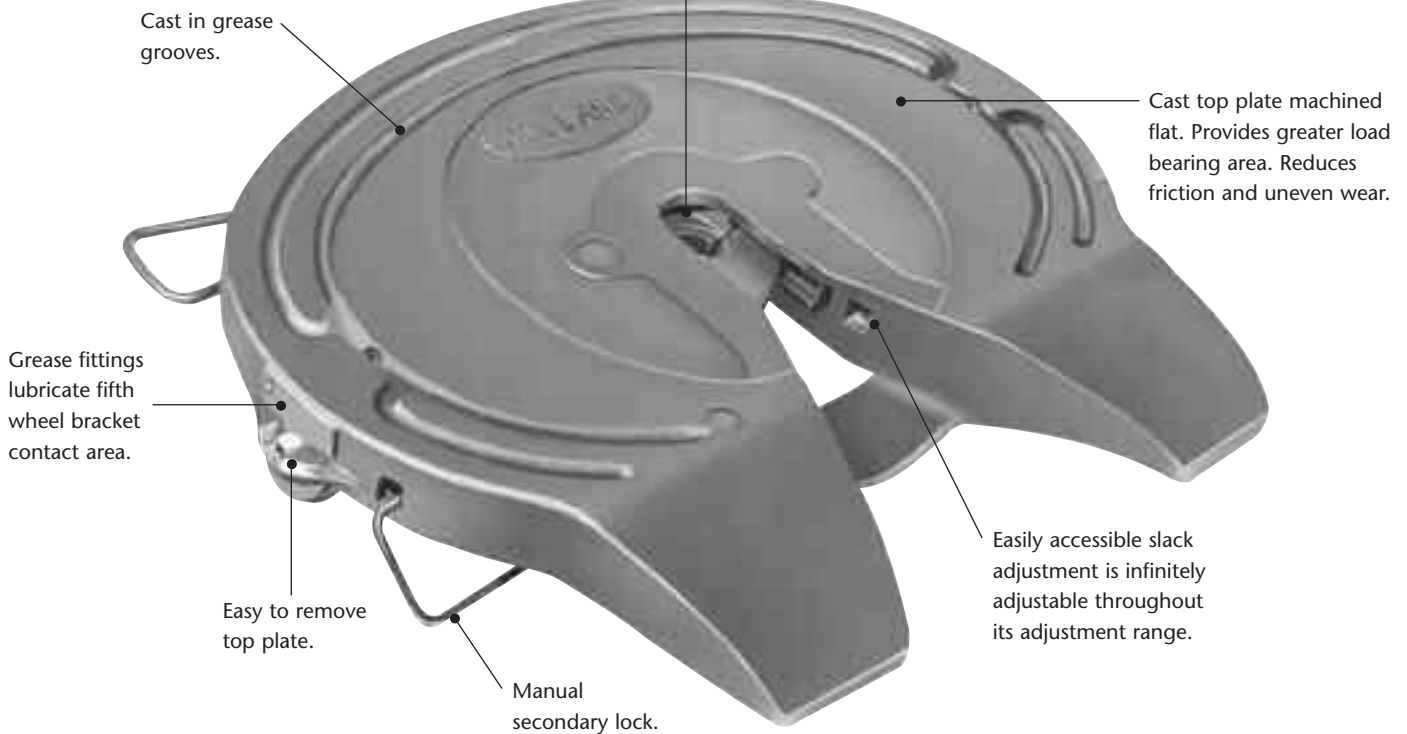

MOUNTING SYSTEMS

STANDARD CAPACITY FIFTH WHEELS

Stationary Mount Brackets

Outboard Angle Mounting Style

Bracket with Mounting Base

Special base designed for bolt-on applications. Hole pattern is designed for more clearance when mounting on inboard and outboard angles or corrugated mounting plate.

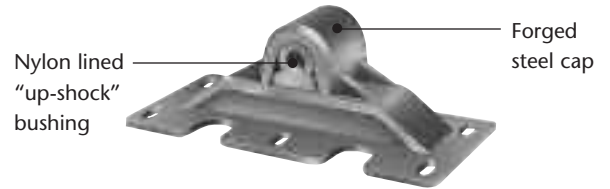

Lightweight Base

Lightweight base designed for bolt-on outboard angle mounting applications. Utilizes universal hole pattern for outboard angle mounting. When used with Holland XA-05044 outboard mounting angles:

1. Hole pattern allows for 2" increments of fore and aft positioning.
2. Accommodates frame widths from 33.25" to 34.75".

Note: For more information on Holland mounting angles for outboard angle mount stationary or sliding fifth wheels, see Holland "Suggested List Prices for Fifth Wheels."

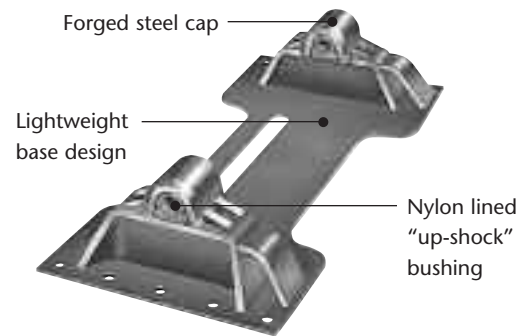

Over-the-frame Mounting Style

Bracket for Mounting Angle

Designed for welding to angles at installation.

Bracket with Mounting Angle

Standard 4" x 4" x .38" x 36" long. Various heights and frame widths available.

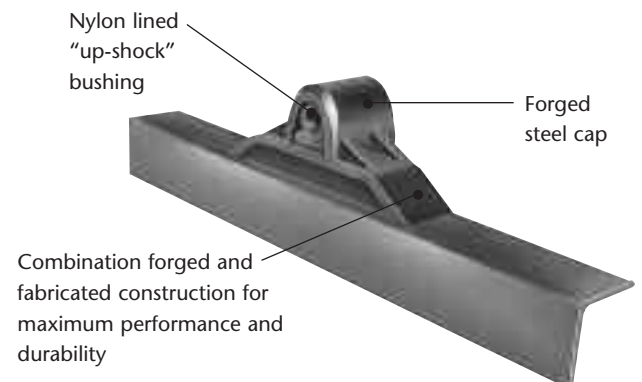
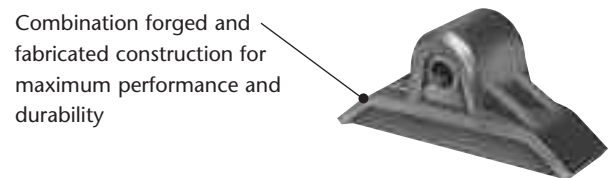

MOUNTING SYSTEMS

STANDARD CAPACITY FIFTH WHEELS

Slide Bracket and Plate Assemblies

Slide Brackets

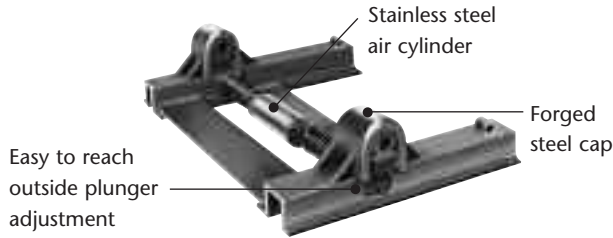

AIR RELEASE

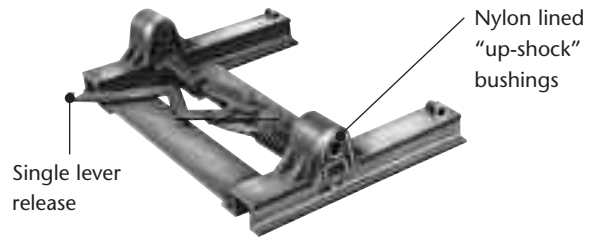

MANUAL RELEASE

Slide Plates

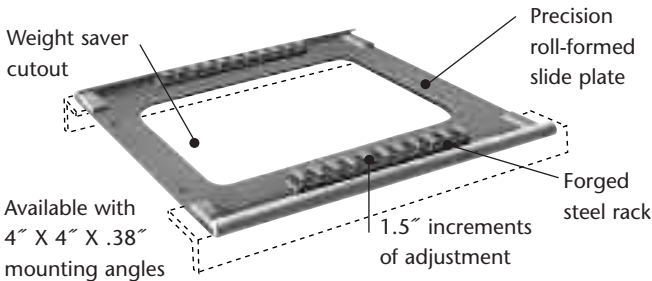

OVER-THE-FRAME MOUNT

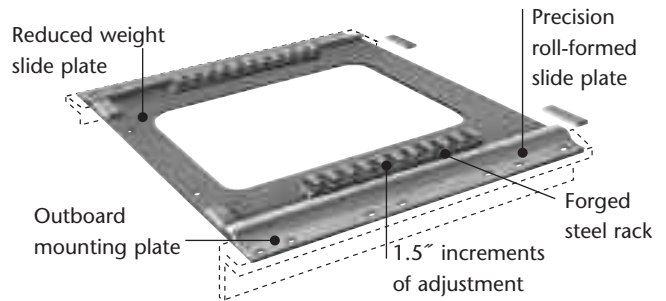

OUTBOARD ANGLE MOUNT



ILS® Slide Bracket and Plate Assemblies

New, lightweight, no welding modular base design, offering significant weight savings with easy height change.

- Single-piece, bolt-on cast bracket (low cost, low weight, and easily replaceable)
- Two-piece side cushioning "upshock" bushings
- Slide-on (no weld), repositionable bulk head fitting bracket
- Same cylinder location on all heights (includes "quick-connect" fittings)
- 2" slide increments
- Universal "tie plate"
- "Bolt-on" slide stops



OUTBOARD ANGLE MOUNT



INBOARD ANGLE MOUNT



DIRECT MOUNT

HEAVY DUTY STATIONARY FIFTH WHEELS

SEVERE DUTY FW0100 Series

Capacity:

100,000 lbs. Maximum Vertical Load
200,000 lbs. Maximum Drawbar Pull

Application:

Designed primarily for high capacity requirements, such as permit hauls, off-road, oilfield rig-ups, etc.

Features:

Top Plate (XA-101)

Cast steel with Type "A", 2" or 3.5" SAE kingpin locks, manual secondary lock. Left-hand release only.

Bracket Design

Heavy cast or fabricated steel bracket with mounting base.

Fifth Wheel Heights

9", 10.5"

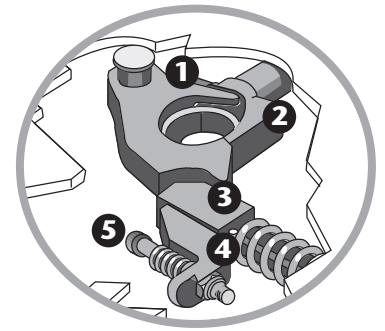

TYPE "A" LOCKING SYSTEM

- 1 Swinging Lock
- 2 Front Lock
- 3 Plunger
- 4 Adjusting Wedge
- 5 Plunger

Locks require only 300 lbs. to couple. Available for 2" or 3.5" SAE kingpins.

Cast in grease grooves.

Cast top plate machined flat. Provides greater load bearing area. Reduces friction and uneven wear.

Easily accessible slack adjustment is infinitely adjustable throughout its adjustment range.

FW0165 Series

Capacity:

165,000 lbs. Maximum Vertical Load
200,000 lbs. Maximum Drawbar Pull

Application:

Our highest capacity fifth wheel.

Features:

Top Plate (XA-101)

Cast and fabricated steel with Type "A", 2" or 3.5" SAE kingpin locks, manual secondary lock. Left-hand release only.

Bracket Design

Heavy cast steel bracket with mounting base.

Fifth Wheel Height

10.5"



XA-101 Top Plate

MOUNTING

MOUNTING STYLES

KOMPENSATOR® FIFTH WHEELS

STANDARD DUTY

FleetMaster Series (FW8)

3500 Series (FW35)

Stationary Over-the-Frame Mount or Outboard Angle Mount

Capacity:

FW8 - 50,000 lbs. Maximum Vertical Load

FW35 - 55,000 lbs. Maximum Vertical Load

All Models - 150,000 lbs. Maximum Drawbar Pull

Application:

Designed for applications such as bulk tankers, lowboys, B-trains, bottom dumps, grain trailers, rigid trailers that don't flex during torsional loading. This rigidity during operation promotes problems such as tank cracking and leaking, tractor frame cracks, and premature drive tire wear. The patented Kompensator provides torsional stress relief and promotes vehicle stability in trailers where the center of gravity is up to 44 inches above the top plate surface. Its unique cradle design provides side-to-side oscillation to help relieve the torque and twist. Its spring cushions act as a restoring force to provide stability after absorbing the strain and pressure. It keeps the center of compensation above the fifth wheel bearing surface and centered between the frame rails.

Features:

Mounting Styles

- Base for angle mounting
- Base with mounting angles
- Base with full mounting plate
- Base with I.S.O. mounting
- Base for outboard angle mounting

Top Plate

Cast steel with Type "A" or Type "B" locks. Designed for 2" SAE J700b kingpins.

Fifth Wheel Heights

9.76" to 12.76" depending upon mounting style.

Optional "Lock Out"

All models are available with an optional "lock out" feature to restrict compensation for use with van type trailers.



FW8 Series Kompensator with
OTF Angle Mount

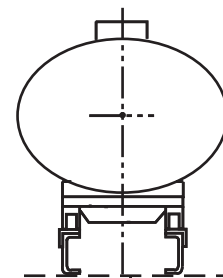
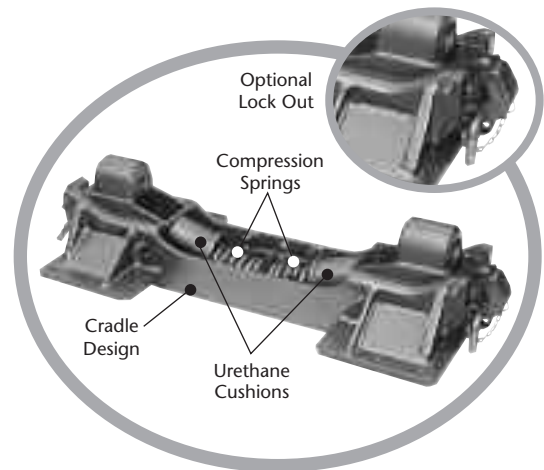

STANDARD FIFTH WHEEL
ON LEVEL GROUND

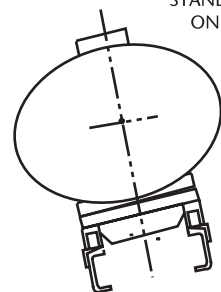

STANDARD FIFTH WHEEL
PASSING OVER CURB

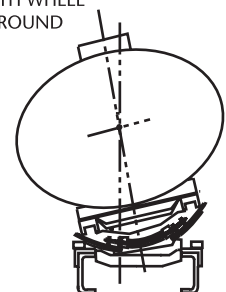

KOMPENSATOR® PASSING
OVER CURB

MOUNTING STYLES

KOMPENSATOR® FIFTH WHEELS

FW7040 Series

Stationary Over-the-Frame Mount or Outboard Angle Mount

Capacity:

70,000 lbs. Maximum Vertical Load
200,000 lbs. Maximum Drawbar Pull

Application:

Designed for applications like the standard capacity Kompensators, but where there is a need for greater capacities.

Features:

Mounting Styles

- Base for angle mounting
- Base with mounting angles
- Base with full mounting plate
- Base with I.S.O. mounting
- Base for outboard angle mounting

Top Plate

Cast steel with 2" or 3.5" SAE kingpin locks and manual secondary lock. Left-hand release only.

Fifth Wheel Heights

9.39" to 12.76" depending upon mounting style.

Optional "Lock Out"

All models are available with an optional "lock out" feature to restrict compensation for use with van type trailers.



FW7040 Series Kompensator with
OTF Angle Mount

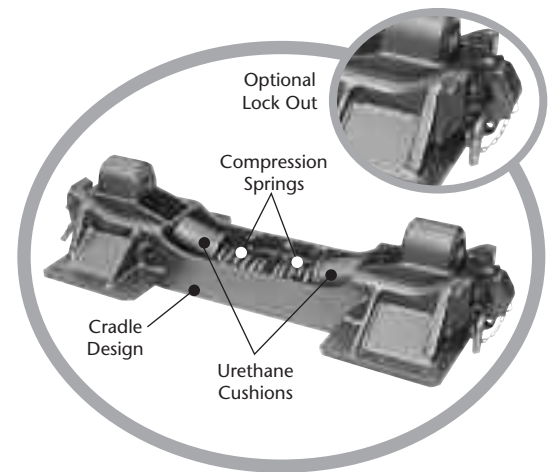

MOUNTING

MOUNTING STYLES

OSCILLATING FIFTH WHEELS

FW1560-B Series

Capacity:

40,000 lbs. Maximum Vertical Load
150,000 lbs. Maximum Drawbar Pull

Application:

For applications where minimizing torque and twist transfer through the fifth wheel is beneficial. Used where center of gravity is equal to or below fifth wheel height.

Features:

Top Plate

Cast steel, Type "B" locks. Designed for 2" SAE J700b kingpins.

Base Design

Cast steel rocker sub-assembly mounted on a corrugated plate.

Fifth Wheel Height

11.06"

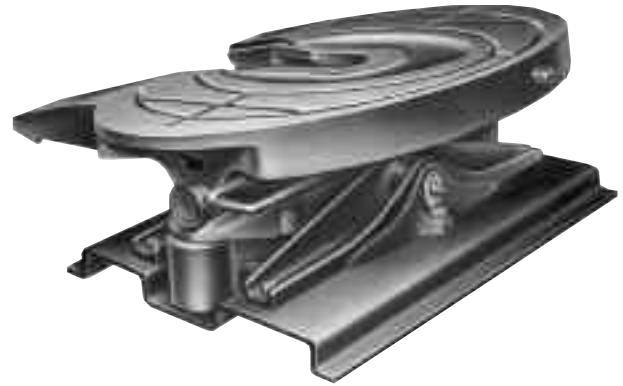

FW1560-B

FW2080 Series

Capacity:

70,000 lbs. Maximum Vertical Load
200,000 lbs. Maximum Drawbar Pull

Application:

Our highest capacity oscillating fifth wheel. Used where center of gravity is equal to or below fifth wheel height.

Features:

Top Plate

Cast steel with Type "A", 2" or 3.5" SAE kingpin locks, manual secondary lock. Left-hand release only.

Base Design

Heavy cast steel rocker construction with cast steel brackets. Available with optional side-to-side lockout.

Fifth Wheel Height

13.62"

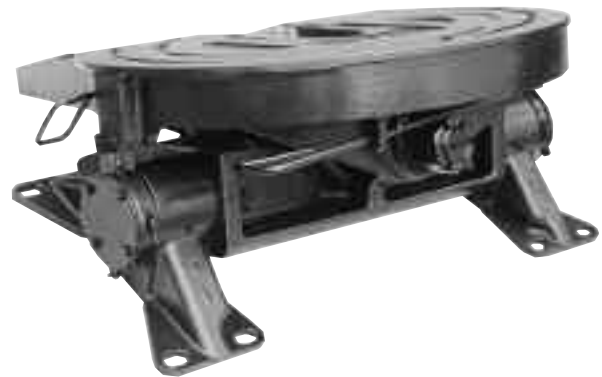

FW2080 Series

MOUNTING STYLES

YARD SPOTTER FIFTH WHEELS

FW35-03344 Series

Capacity:

70,000 lbs. Vertical Capacity

Application:

For use in standard yard spotter applications where a semi-oscillating fifth wheel meets the requirements.

Features:

Top Plate

Cast steel XA-3501 Series with air operated Type "B" locks and hardened steel pocket liners.

Bracket Design

Fabricated steel brackets with cast steel bracket caps.

Fifth Wheel Heights

8", 10"



FW35-03344 Series

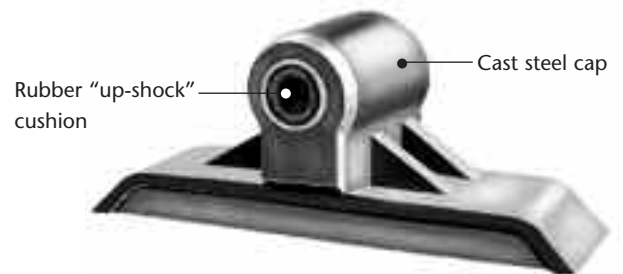

Rubber "up-shock" cushion

Cast steel cap

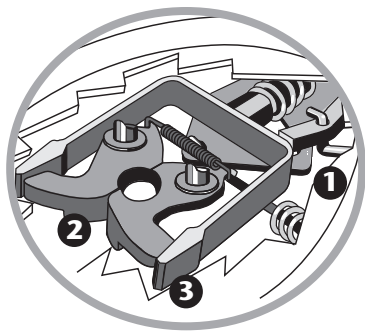

TYPE "B" LOCKING SYSTEM

- ① Manual Secondary Lock
- ② Forged Steel, Heat-Treated Split Locks
- ③ Forged Steel, Heat-Treated Yoke

FW2870-03184 Series

Capacity:

100,000 lbs. Maximum Vertical Load

Application:

For use in demanding yard spotter applications such as railyard, piggyback or marine terminal operations where extra-capacity semi-oscillating fifth wheels are required.

Features:

Top Plate

Heavy-duty fabricated steel with air operated Type "B" locks and replacement bracket bushings.

Bracket Design

Fabricated steel brackets with cast steel bracket caps and hardened steel pocket liner

Fifth Wheel Heights

6.5", 8"



FW2870-03184 Series

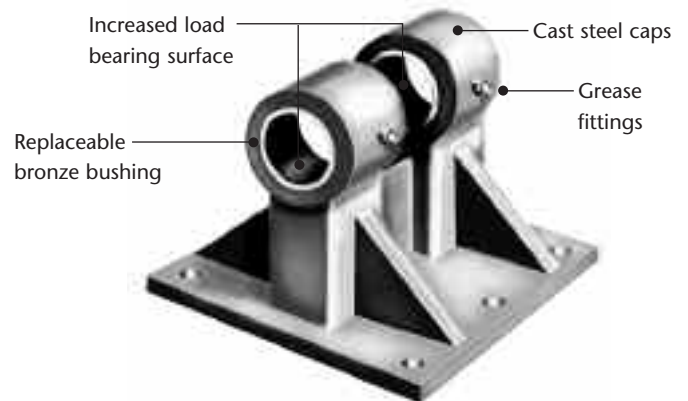

Increased load bearing surface

Cast steel caps

Replaceable bronze bushing

Grease fittings

MOUNTING

MOUNTING STYLES

YARD SPOTTER FIFTH WHEELS

FW1560-C Series

Capacity:

50,000 lbs. Vertical Capacity

Application:

For use on yard spotter tractors in applications where a fully oscillating fifth wheel is required to minimize torque and twist transfer through the fifth wheel. Applications such as railyard, piggyback, marine container handling, interplant freight or where used in rough terrain.

Features:

Top Plate

Cast steel with air operated Type "B" locks.

Bracket Design

Cast steel rocker assembly on a reinforced corrugated 38" steel mounting plate.

Fifth Wheel Height

11.06"

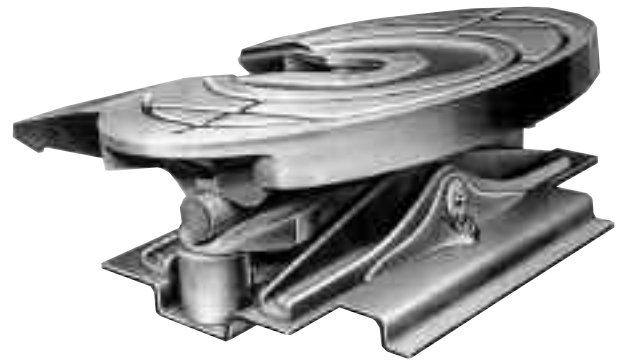
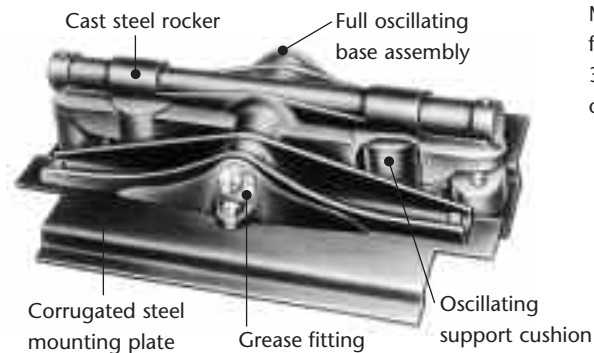

FW1560-C

Cast steel top plate machined flat. Provides greater load bearing area. Reduces friction and uneven wear.

Cast in grease grooves

Machined and heat-treated forged steel locks provide a 360° grip on kingpin. Requires only 300 lbs. to couple.

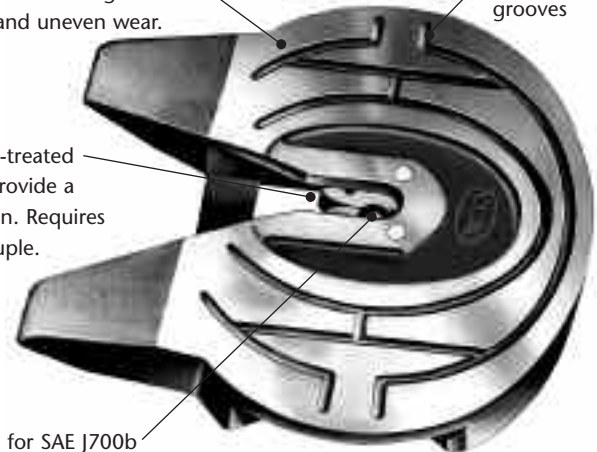

Designed for SAE J700b (2") kingpins

SPECIAL FEATURE FIFTH WHEELS

FW1226 Rigid Type

Capacity:

40,000 lbs. Maximum Vertical Load

150,000 lbs. Maximum Drawbar Pull

Application:

Applications requiring a fixed, non-articulating fifth wheel.

Features:

Top Plate

Cast steel, Type "A" locks. Designed for 2" SAE J700b kingpins.

Fifth Wheel Height

4.25"



FW1226

NO-TILT CONVERTIBLE FIFTH WHEELS



3500 Series (FW35)

Over-the-Frame and Outboard Angle Mounts
Stationary and Sliding

Capacity:

55,000 lbs. Maximum Vertical Load
150,000 lbs. Maximum Drawbar Pull

Extra Capacity Series

FW0070 Series Capacity

Stationary Outboard Angle Mount only:

70,000 lbs. Maximum Vertical Load
200,000 lbs. Maximum Drawbar Pull

FW2570 Series Capacity

Sliding Over-the-Frame Mount only:

70,000 lbs. Maximum Vertical Load
150,000 lbs. Maximum Drawbar Pull

Application:

A specialty fifth wheel, designed for use with frameless dump trailers equipped with oscillating upper couplers. Available in stationary or sliding models with a choice of XA-201 or XA-351 Series Top Plates

Features:

The frameless dump trailer requires a non-oscillating fifth wheel because articulation is provided by the upper coupler configuration. This fifth wheel can be converted from the no-tilt model to the standard semi-oscillating model for use with a conventionally equipped trailer by simply removing the no-tilt shaft. This fifth wheel accommodates fleets using both framed and frameless trailers.

No-tilt installation kits for stationary fifth wheels are available to convert standard semi-oscillating fifth wheel to convertible no-tilt models.

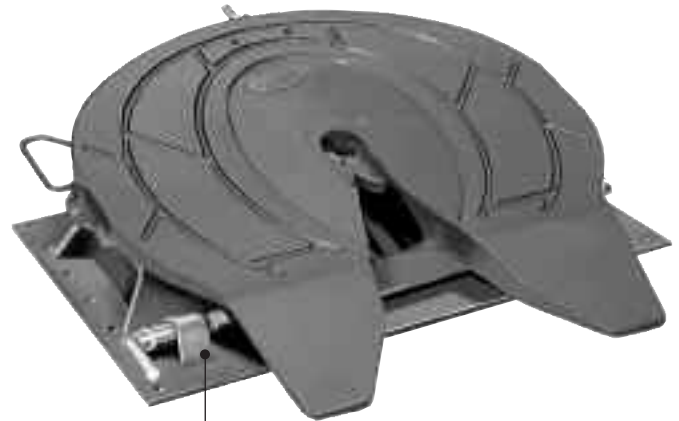

FW35 Stationary No-Tilt,
Outboard Angle Mount

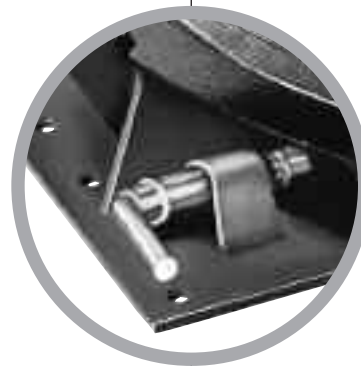

Removable
no-tilt shaft



FW0070 Stationary No-Tilt,
Outboard Angle Mount

MOUNTING SYSTEMS

"NO-TILT" CONVERTIBLE FIFTH WHEELS

No-Tilt Stationary Mount Brackets

Flat Plate Mount

3/8" Mounting Plate

Mounting base can be inboard or outboard angle mounted. The no-tilt brackets will require welding at installation.

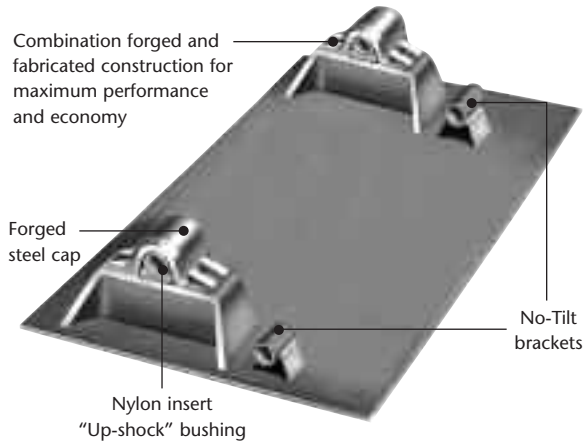

Outboard Angle Mount

1/2" Mounting Plate

Ready to mount – does not require any welding

Base is designed for outboard angle mounting bolt-on applications. Utilizes universal hole pattern for outboard angle mountings. The mount plate has 14 holes on 4" centers, 7 per side, with 3 7/8" width across holes.

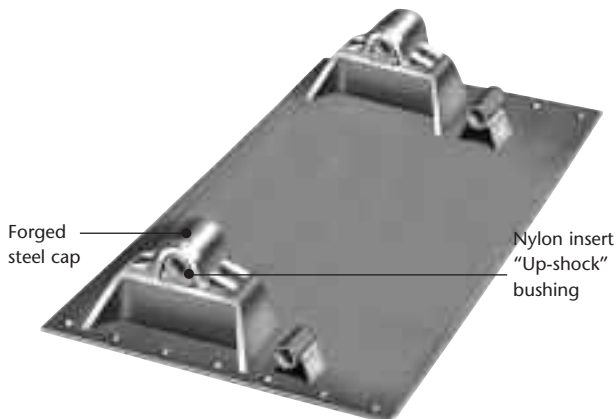

Slide Bracket and Plate Assemblies

Slide Brackets

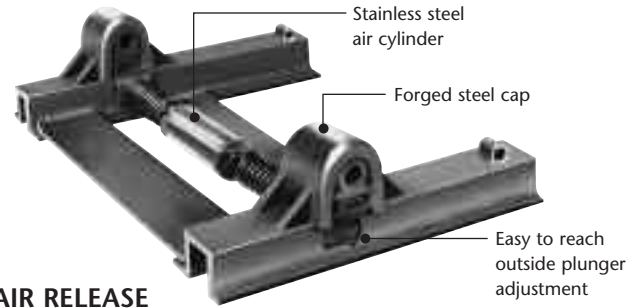

AIR RELEASE

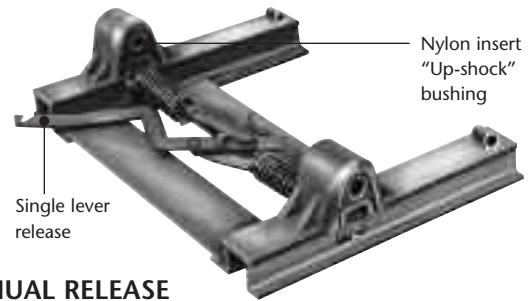

MANUAL RELEASE

Slide Plates

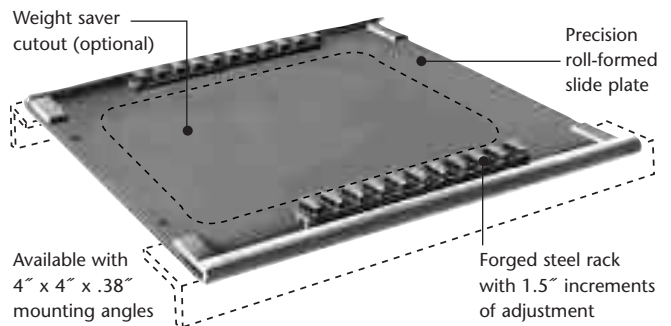

OVER-THE-FRAME MOUNT

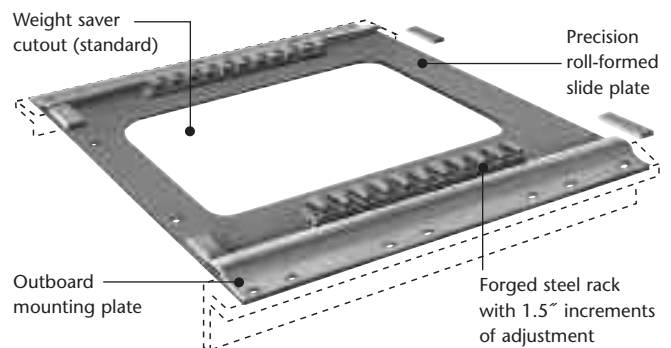

OUTBOARD ANGLE MOUNT

“MOV-ON” ELEVATING FIFTH WHEELS

Air Elevating

Capacity:

40,000 lbs. Vertical Lift

Applications:

Converts a standard road tractor for low-cost, efficient yard spotting, switching and hauling. Used by truck fleet terminals, railyard piggyback operations, marine terminal container handling, interplant freight, industrial material handling and shipping operations.

Features:

- 16" lift height.
- Low cost solution to your trailer spotting problem.
- Ease of maintenance - bushed pivot points and fewer moving parts.
- Lower maintenance cost - simplicity of pneumatic lift system.
- Utilizes air system already on vehicle.
- Lifts load straight up - minimum lift swing.
- Operates efficiently in all climates.
- Easily accessible grease fitting at pivot points.
- Holland Type B locks - specially designed for the excessive lock/unlock demands of the yard tractor. Locks are forged alloy steel, machined and heat treated for maximum wear and toughness.

Note: Mounting angles included with unit.

Hydraulic Elevating

Capacity:

50,000 - 100,000 lbs. Vertical Lift

Features:

- Available with single cylinder (50,000 lbs. lift capacity) and twin cylinder (100,000 lbs. lift capacity).
- A variety of lift heights - 14", 15", 18.5" and 19.5".
- Equipped with 8" I.D. double action hydraulic cylinders (pump up/pump down). Cold weather won't affect lowering of fifth wheel.
- Optional air operated lift control kit for ease of operation.
- Rigid, rugged construction. Weight is carried directly over the tractor frame for maximum support and efficient load distribution.
- Easily accessible grease fittings for ease of maintenance.
- Holland Type B locks, specially designed for the excessive lock /unlock demands of the yard tractor. Locks are forged alloy steel, machined and heat treated for maximum wear and toughness.
- For frequent over-the-road usage on public streets or highways, the FW2800-X and FW2900-X models are available with a lock down option (specify Option Code "87").

Note: Mounting angles, oil tank and filter included with basic unit.

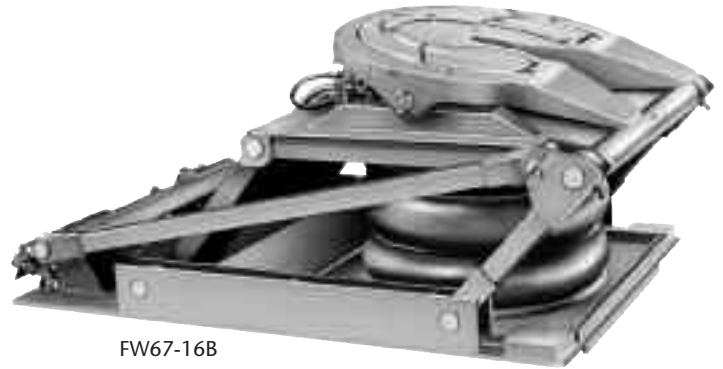

FW67-16B

Specifications:

- Four-ply hypolon-coated air bags operate at maximum pressure of 145 pounds.
- To be used with 24 CFM air compressor for maximum lift efficiency, but may be used with a dedicated 16 CFM (minimum) unit.
- Nine cubic foot air tank included.
- Top of frame mounting.
- Equipped with manual secondary lock.



FW2800-5X

Specifications:

- Bearing areas and moving parts are oversized to minimize wear.
- P.T.O. ratio of 1:1 recommended for all units; 100% of engine RPM.
- 17 GPM (at 1300 rpm) pump provided with single cylinder units.
- 20 GPM (at 1300 rpm) pump provided with twin cylinder units. Both systems designed to operate at 1800 psi maximum.
- Equipped with manual secondary lock.

Hydraulic Lift Accessories:

- RK-2800-10-G* Hydraulic control valve for all single cylinder models.
 - RK-2800-20-G Hose and fittings for single cylinder models.
 - RK-2800-30-G Hose and fittings for twin cylinder models.
 - RK-2800-40-G* Hydraulic control valve and flange kits for twin cylinder models.
 - RK-2800-50 Air operated lift control for all models (optional).
- * For RK-2800-10-G and RK-2800-40-G, the PTO must be ordered separately. PTO (XB-2781-1) requires information on the make, model and year of the tractor, and make and model of the transmission.

LIGHT COMMERCIAL FIFTH WHEELS

FW1900 Series

Capacity:

20,000 lbs. Maximum Vertical Load
40,000 lbs. Maximum Gross Trailer Weight

Applications:

Specially designed for economical use with light commercial vans and flats or gooseneck-type trailers.

Features:

Mounting Styles

Conventional

This installation uses the FW6000-20, FW0001 or FW1900-20. The assembly consists of a fifth wheel and brackets attached to a mounting plate and bolted to the frame of the tow vehicle.

Inverted

This installation uses the FW6000-10 or FW0001. The FW6000-10 assembly consists of a fifth wheel with mounting brackets in the inverted position attached to a XA-6510 adjustable height mounting box attached to the trailer frame. The assembly is used in combination with a KP-6500 fixed kingpin and plate assembly or a KP-6610 folding kingpin and plate assembly.

Lock Mechanism

Type "B" locks are forged alloy steel, machined for accuracy and heat-treated for wear and toughness. Locks provide 360 degree grip on the kingpin for long lock and kingpin life.

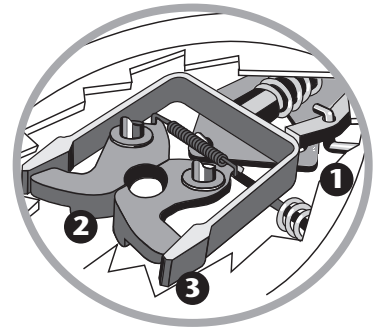

TYPE "B" LOCKING SYSTEM

- ① Manual Secondary Lock
- ② Forged Steel, Heat-Treated Split Locks
- ③ Forged Steel, Heat-Treated Yoke

FW1900

Infinite lock adjustment positions (not stepped) provide improved lock and kingpin durability.

Lock adjustment nut is readily accessible providing ease of maintenance.

Single action lock release for low operating effort.

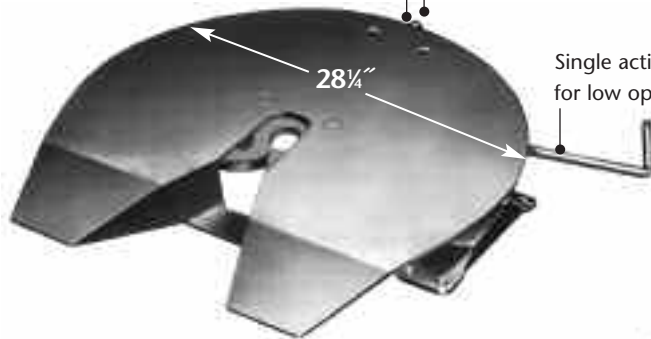

FW1900-20

With XA-6520-A Mounting Plate is designed to be bolted to the truck frame or frame-mounted attachments.



Models Available

MODEL	NOMINAL F.W. HEIGHT	APPROX. WEIGHT
FW1900	5.00"	129 lbs.
FW1900-20	5.94"	246 lbs.
*FW1900-LH	5.00"	129 lbs.

* "LH" is left-hand release

LIGHT COMMERCIAL FIFTH WHEELS

FW6000 Series

Capacity:

12,000 lbs. Maximum Vertical Load
32,000 lbs. Maximum Gross Trailer Weight

Models Available

MODEL	NOMINAL F.W. HEIGHT	APPROX. WEIGHT
FW6000	5.00"	119 lbs.
FW6000-10	Adjustable	256 lbs.
FW6000-20	5.94"	236 lbs.

FW6000

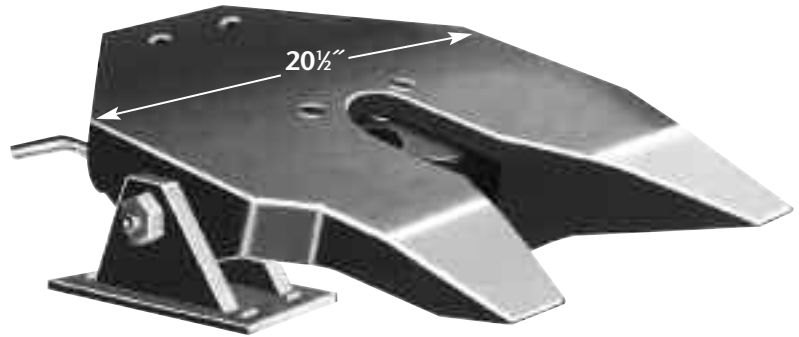

The XA-6520 Mounting Plate is designed to be bolted to the truck frame or frame-mounted attachments.



The XA-6510 Adjustable Box is designed to be welded to the trailer frame. 6" height adjustment in 2" intervals.

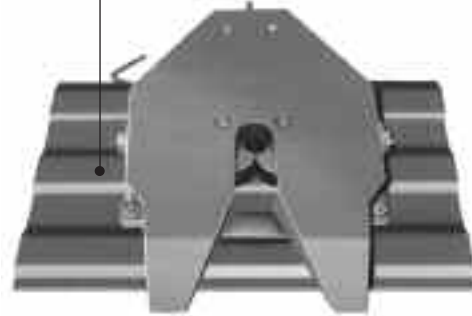

FW6000-10

With XA-6510 Adjustable Mounting Box

FW6000-20

With XA-6520 Mounting Plate

FW0001 Series

Capacity:

8,000 lbs. Maximum Vertical Load
32,000 lbs. Maximum Gross Trailer Weight

FW0001

Tube type gooseneck and box type gooseneck installation.



FW0002

Double axis tube type and box type gooseneck installations.



Models Available

MODEL	NOMINAL F.W. HEIGHT	GOOSENECK TUBE OR BOX DIA.	APPROX. WEIGHT
FW0001	5.5"	N/A	60 lbs.
FW0001-35	5.5"	N/A	68 lbs.
FW0001-40	5.5"	N/A	68 lbs.
FW0001-45	5.5"	N/A	68 lbs.
FW0002-35	5.5"	3.5"	68 lbs.
FW0002-40	5.5"	4.0"	68 lbs.
FW0002-45	5.5"	4.5"	68 lbs.

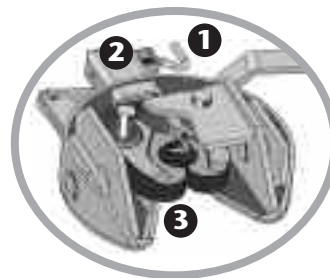

LOCKING SYSTEM

- 1 Safety Lock Handle
- 2 Ductile Iron Locking Block
- 3 Ductile Iron Cast Split Locks

ACCESSORIES

FOR FW1900 AND FW6000 FIFTH WHEELS

KP-6500

The KP-6500 adjustable box with 2" kingpin is designed to be welded to the trailer frame. 6" height adjustment in 2" intervals from 13.62" to 19.62".



KP-0030

(Formerly BFW-0030)
Bed mounted, kingpin retractable.



Air Release Systems

Fifth Wheel Lock Release System for Holland FW35, FW3500 and FleetMaster Series Fifth Wheels.

A unique, safe, cab-mounted fifth wheel lock release system.

Clean, Effortless Operation

Eliminates the manual pulling force to release the fifth wheel locks. No more reaching in to grasp the release handle with the risk of greasy hands and clothes.

In-Cab Pneumatic Operation

Drivers can easily and safely release the fifth wheel locks from the tractor cab. With a punch of a button, a pneumatic cylinder on the fifth wheel will open the locks.

Manual Operation

Fifth wheel release handle can be manually operated at any time if needed.

Air Release Kit

XA-351-86-L-P – Includes fifth wheel top plate XA-351-A-80-L and RK-06559 Air Release kit including control module.

Also available with NoLube and LowLube top plates.

Retrofit Applications

The Air Release system can be added to any XA-351 top plate assembly and any XA-3501 top plate assembly produced after January 1, 1993. Order lot RK-07814 for an XA-351 top plate, and RK-07370 for an XA-3501 top plate.

Warranty

The Air Release system is backed by Holland's extensive, five-year parts and labor warranty, unmatched in our industry.

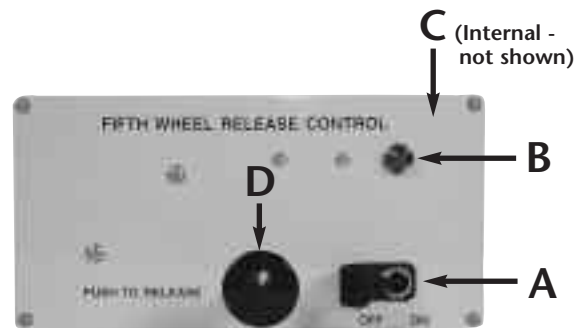
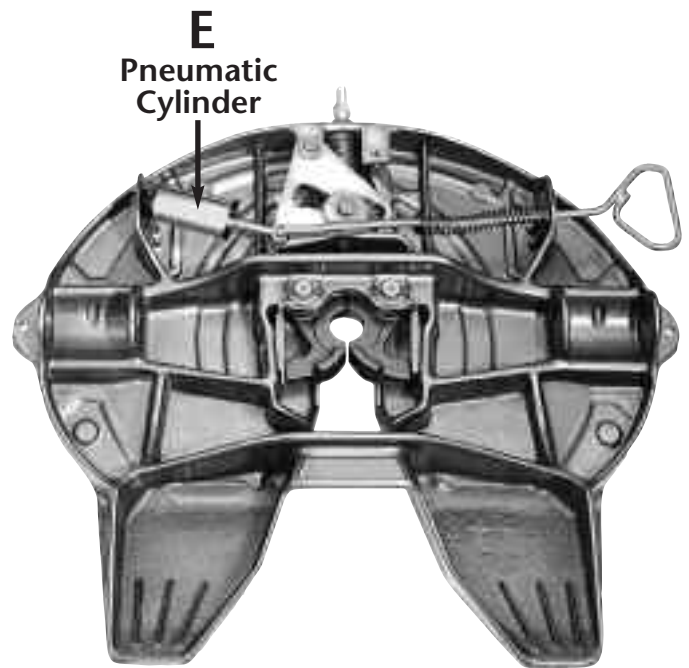

Three-Step, Fail-Safe Operation

Prevents unlocking of the fifth wheel when the tractor and trailer are moving.

The three step system assures that the fifth wheel lock release can only be operated when the tractor and trailer are standing still. The unique air-assisted interlock design absolutely prevents accidental release of the fifth wheel locks.

1. Set the trailer parking brake to activate the Air Release system.
2. Turn the toggle switch (A) to the "ON" position. That activates a visual light (B) and an audible horn (C) indicating that the system is ready to release.
3. Push the fifth wheel Air Release button (D) in to activate the valve, which forces air to the pneumatic cylinder (E) on the fifth wheel, which then opens the locks.

APPLICATION LIMITATIONS

If any single limitation factor is exceeded within a given duty type, you must move up to the next duty level.

Standard Duty

- Weight (GCW):** Less than 95,000 lbs. (43,000 kg.)
Gross Combination Weight (GCW)
- Road Type:** 100% On-Road (maintained concrete or asphalt roads)
- Trailer Type & Axle Limitation:** *Single trailer:* Tandem axle only
“A” Train: Maximum of 3 axles (trailers and dolly converter)
“B” Train: Maximum of 3 axles (lead and “pup” trailer)
- Travel Type:** More than 30 miles (50 km.) between stops

Standard Duty



Moderate Duty

- Weight (GCW):** Less than 115,000 lbs. (52,000 kg.)
Gross Combination Weight (GCW)
- Road Type:** Less than 10% off-road (maintained concrete, asphalt, gravel, or crushed rock roads) with balance on-road
- Trailer Type & Axle Limitation:** *Single trailer:* Tandem and Tri-axle only
“A” Train: Maximum of 4 axles (trailers and dolly converter)
“B” Train: Maximum of 4 axles (lead and “pup” trailer)
- Travel Type:** No minimum mileage between stops (e.g. city pick-up and delivery)

Moderate Duty

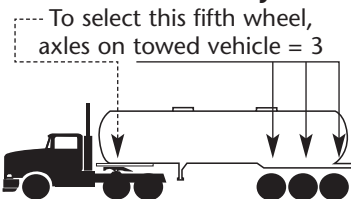

Severe Duty

- Weight (GCW):** More than 115,000 lbs. (52,000 kg.)
Gross Combination Weight (GCW)
- Road Type:** More than 10% off-road (maintained concrete, asphalt, gravel, crushed rock, hard packed dirt, or unimproved/unmaintained roads)
- Trailer Type & Axle Limitation:** *Single trailer:* No axle limitation
“A” Train: No axle limitation
“B” Train: No axle limitation
- Travel Type:** No minimum mileage between stops (e.g. city pick-up and delivery)



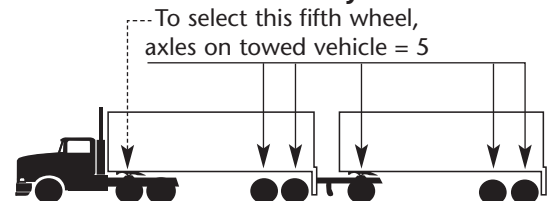



Severe Duty



NOTE: Axle Limitation: When used in this guide to select a fifth wheel, the number of axles (e.g., “Up to 4-axle trains”) refers to the total number of axles on the “towed vehicle(s)” or trailer(s).

FIFTH WHEELS FOR POWER UNITS (TRACTORS)

A. Van Trailers

Standard Duty	Type of Fifth Wheel	Stationary Fifth Wheel		Sliding Fifth Wheel		Rated Fifth Wheel Vertical Capacity	
		Conventional	LowLube or NoLube	Conventional	LowLube or NoLube		
EXAMPLES: Tandem Axle, General Freight, Line Haul, Reefer, Moving Van Up to 3-Axle Trains	Semi-Oscillating	FW8 FW17	FW83	FW8 FW17	FW83	50,000 lbs. (22,700 kg.)	
	Semi-Oscillating	FW35	FW33 FW31	FW35	FW33 FW31	55,000 lbs. (25,000 kg.)	
Moderate Duty	Type of Fifth Wheel	Stationary Fifth Wheel		Sliding Fifth Wheel		Rated Fifth Wheel Vertical Capacity	
		Conventional	LowLube or NoLube	Conventional	LowLube or NoLube		
EXAMPLES: Short Haul ¹ (city pick-up and delivery) Tri-Axle Van Up to 4-Axle Trains	Semi-Oscillating	FW8	FW83	FW8	FW83	50,000 lbs. (22,700 kg.)	
	Semi-Oscillating	FW35	FW33	FW35	FW33	55,000 lbs. (25,000 kg.)	
	Semi-Oscillating			FW2555		62,500 lbs. (28,400 kg.)	
	Semi-Oscillating	FW0070		FW2570		70,000 lbs. (31,750 kg.)	
Severe Duty*	Type of Fifth Wheel	Stationary Fifth Wheel		Sliding Fifth Wheel		Rated Fifth Wheel Vertical Capacity	
		Conventional	LowLube or NoLube	Conventional	LowLube or NoLube		
EXAMPLES: More than Tri-Axle 5 or More Axle Trains	Semi-Oscillating	FW35		FW35		55,000 lbs. (25,000 kg.)	
	Semi-Oscillating			FW2555		62,500 lbs. (28,400 kg.)	
	Semi-Oscillating	FW0070		FW2570		70,000 lbs. (31,750 kg.)	
	Semi-Oscillating	FW0100				100,000 lbs. (45,350 kg.)	
	Semi-Oscillating	FW0165				165,000 lbs. (74,850 kg.)	

NOTE: 1 Any tractor used for "Short Haul" (e.g., city pick-up and delivery) is to be considered a Moderate Duty Application.

FIFTH WHEELS FOR POWER UNITS (TRACTORS)

B. Tanker & Dry Bulk Trailers²



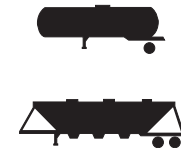



Standard Duty	Type of Fifth Wheel	Stationary Fifth Wheel		Sliding Fifth Wheel		Rated Fifth Wheel Vertical Capacity
		Conventional	LowLube or NoLube	Conventional	LowLube or NoLube	
EXAMPLES: Single Axle Tanker Tandem Axle Tanker Single Axle Dry Bulk Tandem Axle Dry Bulk	Kompensator	FW8	FW83	FW8	FW83	50,000 lbs. (22,700 kg.)
	Semi-Oscillating	FW8 FW17	FW83	FW8 FW17	FW83 ³	50,000 lbs. (22,700 kg.)
	Kompensator	FW35	FW33	FW35	FW33	55,000 lbs. (25,000 kg.)
	Semi-Oscillating	FW35	FW33 FW31	FW35 ³	FW33 ³ FW31	55,000 lbs. (25,000 kg.)
Moderate Duty	Type of Fifth Wheel	Stationary Fifth Wheel		Sliding Fifth Wheel		Rated Fifth Wheel Vertical Capacity
		Conventional	LowLube or NoLube	Conventional	LowLube or NoLube	
EXAMPLES: Short Haul Tanker Tri-Axle Tanker Tri-Axle Dry Bulk Up to 4-Axle Trains	Kompensator	FW35	FW33	FW35	FW33	55,000 lbs. (25,000 kg.)
	Semi-Oscillating	FW35	FW33	FW35	FW33 ³	55,000 lbs. (25,000 kg.)
	Semi-Oscillating			FW2555		62,500 lbs. (28,400 kg.)
	Kompensator	FW7040		FW7090		70,000 lbs. (31,750 kg.)
	Semi-Oscillating	FW0070		FW2570		70,000 lbs. (31,700 kg.)
Severe Duty*	Type of Fifth Wheel	Stationary Fifth Wheel		Sliding Fifth Wheel		Rated Fifth Wheel Vertical Capacity
		Conventional	LowLube or NoLube	Conventional	LowLube or NoLube	
EXAMPLES: Oil Field Tanker More than Tri-Axle 5 or More Axle Trains	Kompensator	FW35		FW35		55,000 lbs. (25,000 kg.)
	Semi-Oscillating	FW35 ⁷		FW35 ^{3,8}		55,000 lbs. (25,000 kg.)
	Semi-Oscillating			FW2555		62,500 lbs. (28,400 kg.)
	Kompensator	FW7040		FW7090		70,000 lbs. (31,750 kg.)
	Semi-Oscillating	FW0070		FW2570		70,000 lbs. (31,750 kg.)



- NOTE:**
- Any tractor used for "Short Haul" (e.g., city pick-up and delivery) is to be considered a Moderate Duty Application.
 - A Kompensator fifth wheel is recommended for this application. The unique Kompensator fifth wheel helps relieve twist and torque transmitted by the trailer. Benefits include improved tire life and a reduction in tractor, trailer and tank cracks. This fifth wheel can only be used where the loaded c.g. of the trailer is no more than 44" (1100mm) above the fifth wheel.
 - 24" long slide brackets recommended.
 - Severe Duty applications require "7500" Series brackets.
 - Severe Duty applications require "7000" Series slide plates.

FIFTH WHEELS FOR POWER UNITS (TRACTORS)

C. Flatbed, Stretch and Pole Trailers

Standard Duty	Type of Fifth Wheel	Stationary Fifth Wheel		Sliding Fifth Wheel		Rated Fifth Wheel Vertical Capacity	
		Conventional	LowLube or NoLube	Conventional	LowLube or NoLube		
EXAMPLES: All Single & Tandem Axle Trailers Line Haul Stake & Rack	Semi-Oscillating	FW8 FW17	FW83	FW8 FW17	FW83	50,000 lbs. (22,700 kg.)	
	Semi-Oscillating	FW35	FW33 FW31	FW35	FW33 FW31	55,000 lbs. (25,000 kg.)	
Moderate Duty	Type of Fifth Wheel	Stationary Fifth Wheel		Sliding Fifth Wheel		Rated Fifth Wheel Vertical Capacity	
		Conventional	LowLube or NoLube	Conventional	LowLube or NoLube		
EXAMPLES: Short Haul ¹ Tri-Axle Trailer Up to 4-Axle Trains	Semi-Oscillating	FW8	FW83	FW8	FW83	50,000 lbs. (22,700 kg.)	
	Semi-Oscillating	FW35	FW33	FW35	FW33	55,000 lbs. (25,000 kg.)	
	Semi-Oscillating			FW2555		62,500 lbs. (28,400 kg.)	
	Semi-Oscillating	FW0070		FW2570		70,000 lbs. (31,750 kg.)	
Severe Duty*	Type of Fifth Wheel	Stationary Fifth Wheel		Sliding Fifth Wheel		Rated Fifth Wheel Vertical Capacity	
		Conventional	LowLube or NoLube	Conventional	LowLube or NoLube		
EXAMPLES: More than Tri-Axle 5 or More Axle Trains	Semi-Oscillating	FW35 ⁷		FW35 ⁸		55,000 lbs. (25,000 kg.)	
	Semi-Oscillating			FW2555		62,500 lbs. (25,000 kg.)	
	Semi-Oscillating	FW0070		FW2570		70,000 lbs. (31,750 kg.)	
	Semi-Oscillating	FW0100				100,000 lbs. (45,350 kg.)	
	Semi-Oscillating	FW0165				165,000 lbs. (74,850 kg.)	

- NOTE:**
- 1 Any tractor used for "Short Haul" (e.g., city pick-up and delivery) is to be considered a Moderate Duty Application.
 - 7 Severe Duty applications require "7500" Series brackets.
 - 8 Severe Duty applications require "7000" Series slide plates.

FIFTH WHEELS FOR POWER UNITS (TRACTORS)

D. End Dump (Framed) Trailers

IMPORTANT: Improper dumping procedures can generate unusual forces which the fifth wheel is not designed to resist. For more information, see TTMA Technical Bulletin No. 74.

Standard Duty	Type of Fifth Wheel	Stationary Fifth Wheel		Sliding Fifth Wheel		Rated Fifth Wheel Vertical Capacity
		Conventional	LowLube	Conventional	LowLube	
EXAMPLES: All Single & Tandem Axle Trailers Up to 3-Axle Trains	Semi-Oscillating	FW8		FW8		50,000 lbs. (22,700 kg.)
	Semi-Oscillating	FW35		FW35		55,000 lbs. (25,000 kg.)
Moderate Duty	Type of Fifth Wheel	Stationary Fifth Wheel		Sliding Fifth Wheel		Rated Fifth Wheel Vertical Capacity
		Conventional	LowLube	Conventional	LowLube	
EXAMPLES: Short Haul ¹ Tri-Axle Trailer Up to 4-Axle Trains	Semi-Oscillating	FW35		FW35		55,000 lbs. (25,000 kg.)
	Semi-Oscillating			FW2555		62,500 lbs. (28,400 kg.)
	Semi-Oscillating	FW0070		FW2570		70,000 lbs. (31,750 kg.)
Severe Duty*	Type of Fifth Wheel	Stationary Fifth Wheel		Sliding Fifth Wheel		Rated Fifth Wheel Vertical Capacity
		Conventional	LowLube	Conventional	LowLube	
EXAMPLES: More than Tri-Axle 5 or More Axle Trains	Semi-Oscillating	FW35 ⁷		FW35 ^{3,8}		55,000 lbs. (25,000 kg.)
	Semi-Oscillating			FW2555		62,500 lbs. (25,000 kg.)
	Semi-Oscillating	FW0070		FW2570		70,000 lbs. (31,750 kg.)
	Semi-Oscillating	FW0100				100,000 lbs. (45,350 kg.)
	Semi-Oscillating	FW0165				165,000 lbs. (74,850 kg.)



- NOTE:**
- 1 Any tractor used for "Short Haul" (e.g., city pick-up and delivery) is to be considered a Moderate Duty Application.
 - 3 24" long slide brackets recommended.
 - 7 Severe Duty applications require "7500" Series brackets.
 - 8 Severe Duty applications require "7000" Series slide plates.

FIFTH WHEELS FOR POWER UNITS (TRACTORS)

E. End Dump (Frameless) Trailers

IMPORTANT: Improper dumping procedures can generate unusual forces which the fifth wheel is not designed to resist. For more information, see TTMA Technical Bulletin No. 74.

Standard Duty	Type of Fifth Wheel	Stationary Fifth Wheel		Sliding Fifth Wheel		Rated Fifth Wheel Vertical Capacity
		Conventional	LowLube	Conventional	LowLube	
EXAMPLES: All Single & Tandem Axle Trailers	Rigid Mount	FW1226 ⁴				40,000 lbs. (18,150 kg.)
	No-Tilt Convertible	FW35 ⁴		FW35 ⁴		55,000 lbs. (25,000 kg.)
Moderate Duty	Type of Fifth Wheel	Stationary Fifth Wheel		Sliding Fifth Wheel		Rated Fifth Wheel Vertical Capacity
		Conventional	LowLube	Conventional	LowLube	
EXAMPLES: Short Haul ¹ Tri-Axle Trailer Up to 4-Axle Trains	No-Tilt Convertible	FW35 ⁴		FW35 ⁴		55,000 lbs. (25,000 kg.)
	No-Tilt Convertible	FW0070 ⁴		FW2570 ⁴		70,000 lbs. (31,750 kg.)
Severe Duty*	Type of Fifth Wheel	Stationary Fifth Wheel		Sliding Fifth Wheel		Rated Fifth Wheel Vertical Capacity
		Conventional	LowLube	Conventional	LowLube	
EXAMPLES: More than Tri-Axle 5 or More Axle Trains	No-Tilt Convertible	FW35 ⁴		FW35 ⁴		55,000 lbs. (25,000 kg.)
	No-Tilt Convertible	FW0070 ⁴		FW2570 ⁴		70,000 lbs. (31,750 kg.)



- NOTE:**
- Any tractor used for "Short Haul" (e.g., city pick-up and delivery) is to be considered a Moderate Duty Application.
 - Trailers equipped with an oscillating/articulating bolster (kingpin) plate require a non-articulating fifth wheel (such as a rigid or no-tilt convertible).

FIFTH WHEELS FOR POWER UNITS (TRACTORS)

F. Side Dump Trailers

IMPORTANT: Improper dumping procedures can generate unusual forces which the fifth wheel is not designed to resist. For more information, see TTMA Technical Bulletin No. 74.





Standard Duty	Type of Fifth Wheel	Stationary Fifth Wheel		Sliding Fifth Wheel		Rated Fifth Wheel Vertical Capacity
		Conventional	LowLube	Conventional	LowLube	
EXAMPLES: All Single & Tandem Axle Trailers	No-Tilt	FW35°		FW35°		55,000 lbs. (25,000 kg.)
Moderate Duty	Type of Fifth Wheel	Stationary Fifth Wheel		Sliding Fifth Wheel		Rated Fifth Wheel Vertical Capacity
		Conventional	LowLube	Conventional	LowLube	
EXAMPLES: Short Haul ¹ Tri-Axle Trailer Up to 4-Axle Trains	No-Tilt	FW35°		FW35°		55,000 lbs. (25,000 kg.)
	Semi-Oscillating	FW0070		FW2570		70,000 lbs. (31,750 kg.)
Severe Duty*	Type of Fifth Wheel	Stationary Fifth Wheel		Sliding Fifth Wheel		Rated Fifth Wheel Vertical Capacity
		Conventional	LowLube	Conventional	LowLube	
EXAMPLES: More than Tri-Axle 5 or More Axle Trains	No-Tilt	FW35°		FW35°		55,000 lbs. (25,000 kg.)
	Semi-Oscillating	FW0070		FW2570		70,000 lbs. (31,750 kg.)



- NOTE:**
- Any tractor used for "Short Haul" (e.g., city pick-up and delivery) is to be considered a Moderate Duty Application.
 - Due to the increased forces developed in side dump operations, only "No-Tilt" model FW35 fifth wheels are approved for this application.

FIFTH WHEELS FOR POWER UNITS (TRACTORS)

G. Bottom Dump Trailers²

Standard Duty	Type of Fifth Wheel	Stationary Fifth Wheel		ILS Sliding Fifth Wheel		Rated Fifth Wheel Vertical Capacity	
		Conventional	LowLube	Conventional	LowLube		
EXAMPLES: Single and Tandem Axle Bottom Dump Up to 3-Axle Trains	Fully Oscillating	FW1560-B				40,000 lbs. (18,150 kg.)	
	Kompensator	FW8	FW83	FW8	FW83	50,000 lbs. (22,700 kg.)	
	Semi-Oscillating	FW8	FW83	FW8	FW83 ³	50,000 lbs. (22,700 kg.)	
	Kompensator	FW35	FW33	FW35	FW33	55,000 lbs. (25,000 kg.)	
	Semi-Oscillating	FW35	FW33	FW35	FW33 ³	55,000 lbs. (25,000 kg.)	
Moderate Duty EXAMPLES: Short Haul ¹ Tri-Axle Bottom Dump Up to 4-Axle Trains	Kompensator	FW8		FW8		50,000 lbs. (22,700 kg.)	
	Kompensator	FW35		FW35		55,000 lbs. (25,000 kg.)	
	Semi-Oscillating	FW35		FW35		55,000 lbs. (25,000 kg.)	
	Semi-Oscillating			FW2555		62,500 lbs. (28,400 kg.)	
	Kompensator	FW7040		FW7090		70,000 lbs. (31,750 kg.)	
	Semi-Oscillating	FW0070		FW2570		70,000 lbs. (31,750 kg.)	
	Fully Oscillating	FW2080 ⁵				70,000 lbs. (31,750 kg.)	
Severe Duty* * Not recommended for the ILS sliding bracket EXAMPLES: More than Tri-Axle 5 or More Axle Trains	Kompensator	FW35		FW35		55,000 lbs. (25,000 kg.)	
	Semi-Oscillating	FW35 ⁷		FW35 ^{3,8}		55,000 lbs. (25,000 kg.)	
	Semi-Oscillating			FW2555		62,500 lbs. (28,400 kg.)	
	Kompensator	FW7040		FW7090		70,000 lbs. (31,750 kg.)	
	Semi-Oscillating	FW0070		FW2570		70,000 lbs. (31,750 kg.)	
	Fully Oscillating	FW2080 ⁵				70,000 lbs. (31,750 kg.)	

- NOTE:**
- Any tractor used for "Short Haul" (e.g., city pick-up and delivery) is to be considered a Moderate Duty Application.
 - The unique Kompensator fifth wheel helps relieve twist and torque transmitted by the trailer. Benefits include improved tire life and a reduction in tractor, trailer and tank cracks. This fifth wheel can only be used where the loaded c.g. of the trailer is no more than 44" (1100mm) above the fifth wheel.
 - 24" long slide brackets recommended.
 - A fully oscillating fifth wheel should only be used when the c.g. is at or below the fifth wheel height.
 - Severe Duty applications require "7500" Series brackets.
 - Severe Duty applications require "7000" Series slide plates.

FIFTH WHEELS FOR POWER UNITS (TRACTORS)

H. Lowboy Trailers²

Standard Duty	Type of Fifth Wheel	Stationary Fifth Wheel		Sliding Fifth Wheel		Rated Fifth Wheel Vertical Capacity
		Conventional	LowLube	Conventional	LowLube	
EXAMPLES: All Single and Tandem Axle Trailers, Equipment Hauler Float	Fully Oscillating	FW1560-B ⁵				40,000 lbs. (18,150 kg.)
	Kompensator	FW8	FW83	FW8	FW83	50,000 lbs. (22,700 kg.)
	Semi-Oscillating	FW8	FW83	FW8 ³	FW83 ³	50,000 lbs. (22,700 kg.)
	Kompensator	FW35	FW33	FW35	FW33	55,000 lbs. (25,000 kg.)
	Semi-Oscillating	FW35	FW33	FW35 ³	FW33 ³	55,000 lbs. (25,000 kg.)
Moderate Duty EXAMPLES: Short Haul ¹ Tri-Axle Bottom Dump Up to 4-Axle Trains	Kompensator	FW8	FW83	FW8	FW83	50,000 lbs. (22,700 kg.)
	Kompensator	FW35	FW33	FW35	FW33	55,000 lbs. (25,000 kg.)
	Semi-Oscillating	FW35	FW33	FW35 ³	FW33 ³	55,000 lbs. (25,000 kg.)
	Semi-Oscillating			FW2555		62,500 lbs. (28,400 kg.)
	Kompensator	FW7040		FW7090		70,000 lbs. (31,750 kg.)
	Semi-Oscillating	FW0070		FW2570		70,000 lbs. (31,750 kg.)
	Fully Oscillating	FW2080 ⁵				70,000 lbs. (31,750 kg.)
Severe Duty* * Not recommended for the ILS sliding bracket EXAMPLES: More than Tri-Axle 5 or More Axle Trains	Kompensator	FW35		FW35		55,000 lbs. (25,000 kg.)
	Semi-Oscillating	FW35 ⁷		FW35 ^{8,3}		55,000 lbs. (25,000 kg.)
	Semi-Oscillating			FW2555		62,500 lbs. (28,400 kg.)
	Kompensator	FW7040		FW7090		70,000 lbs. (31,750 kg.)
	Semi-Oscillating	FW0070		FW2570		70,000 lbs. (31,750 kg.)
	Fully Oscillating	FW2080 ⁵				70,000 lbs. (31,750 kg.)
	Semi-Oscillating	FW0100				100,000 lbs. (45,350 kg.)
	Semi-Oscillating	FW0165				165,000 lbs. (74,850 kg.)



- NOTE:**
- Any tractor used for "Short Haul" (e.g., city pick-up and delivery) is to be considered a Moderate Duty Application.
 - The unique Kompensator fifth wheel helps relieve twist and torque transmitted by the trailer. Benefits include improved tire life and a reduction in tractor, trailer and tank cracks. This fifth wheel can only be used where the loaded c.g. of the trailer is no more than 44" (1100mm) above the fifth wheel.
 - 24" long slide brackets recommended.
 - A fully oscillating fifth wheel should only be used when the c.g. is at or below the fifth wheel height.
 - Severe Duty applications require "7500" Series brackets.
 - Severe Duty applications require "7000" Series slide plates.

FIFTH WHEELS FOR CONVERTER DOLLIES

Dolly design will affect the proper choice of fifth wheel type. For example, some single axle dollies (especially if they have a hinged tongue drawbar) require the use of a rigid or “No-Tilt” fifth wheel. Most tandem axle dollies can be equipped with a semi-oscillating fifth wheel. Check with the dolly manufacturer for specific recommendations or requirements.

Standard Duty	Type of Fifth Wheel	Stationary Fifth Wheel		Rated Fifth Wheel Vertical Capacity
		Conventional	LowLube	
EXAMPLES: All Single and Tandem Axle Pup Trailers	Rigid Mount	FW1226 ⁴		40,000 lbs. (18,150 kg.)
	Semi-Oscillating	FW8 FW17	FW83	50,000 lbs. (22,700 kg.)
	Semi-Oscillating	FW35	FW33	55,000 lbs. (25,000 kg.)
Moderate Duty ²	Type of Fifth Wheel	Stationary Fifth Wheel		Rated Fifth Wheel Vertical Capacity
		Conventional	LowLube	
EXAMPLES: Short Haul ¹ Tanks, Bulk, End Dump and Bottom Dump	Kompensator	FW8 ²		50,000 lbs. (22,700 kg.)
	Kompensator	FW35 ²	FW33	55,000 lbs. (25,000 kg.)
	Semi-Oscillating	FW35		55,000 lbs. (25,000 kg.)
	Kompensator	FW7040		70,000 lbs. (31,750 kg.)
	Semi-Oscillating	FW0070		70,000 lbs. (31,750 kg.)



- NOTE:**
- Any tractor used for “Short Haul” (e.g., city pick-up and delivery) is to be considered a Moderate Duty Application.
 - A Kompensator fifth wheel is recommended for this application. The unique Kompensator fifth wheel helps relieve twist and torque transmitted by the trailer. Benefits include improved tire life and a reduction in tractor, trailer and tank cracks. This fifth wheel can only be used where the loaded c.g. of the trailer is no more than 44” (1100mm) above the fifth wheel.
 - Trailers equipped with an oscillating/articulating bolster (kingpin) plate require a rigid non-articulating fifth wheel.

FIFTH WHEELS FOR B-TRAINS

A. Van, Flatbed and Stretch Trailers²

Standard Duty	Type of Fifth Wheel	Stationary Fifth Wheel		Rated Fifth Wheel Vertical Capacity
		Conventional	LowLube or NoLube	
EXAMPLES: All Single and Tandem Axle Pup Trailers	Kompensator	FW8	FW83	50,000 lbs. (22,700 kg.)
	Semi-Oscillating	FW8 FW17	FW83 FW17	50,000 lbs. (22,700 kg.)
	Kompensator	FW35	FW33	55,000 lbs. (25,000 kg.)
	Semi-Oscillating	FW35	FW33 FW31	55,000 lbs. (25,000 kg.)

Moderate Duty	Type of Fifth Wheel	Stationary Fifth Wheel		Rated Fifth Wheel Vertical Capacity
		Conventional	LowLube or NoLube	
EXAMPLES: Short Haul ¹ Tri-Axle Pup Trailers	Kompensator	FW8	FW83	50,000 lbs. (22,700 kg.)
	Semi-Oscillating	FW8	FW83	50,000 lbs. (22,700 kg.)
	Kompensator	FW35	FW33	55,000 lbs. (25,000 kg.)
	Semi-Oscillating	FW35	FW33	55,000 lbs. (25,000 kg.)
	Semi-Oscillating	FW0070		70,000 lbs. (31,750 kg.)



B. Tank, Bottom Dump

Standard Duty	Type of Fifth Wheel	Stationary Fifth Wheel		Rated Fifth Wheel Vertical Capacity
		Conventional	LowLube or NoLube	
EXAMPLES: All Single and Tandem Axle Pup Trailers	Kompensator	FW35		55,000 lbs. (25,000 kg.)
	Semi-Oscillating	FW35	FW31	55,000 lbs. (25,000 kg.)

Moderate Duty	Type of Fifth Wheel	Stationary Fifth Wheel		Rated Fifth Wheel Vertical Capacity
		Conventional	LowLube or NoLube	
EXAMPLES: Short Haul ¹ Tri-Axle Pup Trailers	Kompensator	FW35		55,000 lbs. (25,000 kg.)
	Kompensator	FW7040		70,000 lbs. (31,750 kg.)



FIFTH WHEELS FOR B-TRAINS

C. End Dump Trailers

Standard Duty	Type of Fifth Wheel	Stationary Fifth Wheel		Rated Fifth Wheel Vertical Capacity
		Conventional	LowLube	
EXAMPLES: All Single and Tandem Axle Pup Trailers	Semi-Oscillating	FW35		55,000 lbs. (25,000 kg.)
Moderate Duty	Type of Fifth Wheel	Stationary Fifth Wheel		Rated Fifth Wheel Vertical Capacity
		Conventional	LowLube	
EXAMPLES: Short Haul ¹ Tri-Axle Pup Trailers	Semi-Oscillating	FW35		55,000 lbs. (25,000 kg.)
	Semi-Oscillating	FW0070		70,000 lbs. (31,750 kg.)



- NOTE:**
- 1 Any tractor used for "Short Haul" (e.g, city pick-up and delivery) is to be considered a Moderate Duty Application.
 - 2 A Kompensator fifth wheel is recommended for this application. The unique Kompensator fifth wheel helps relieve twist and torque transmitted by the trailer. Benefits include improved tire life and a reduction in tractor, trailer and tank cracks. This fifth wheel can only be used where the loaded c.g. of the trailer is no more than 44" (1100mm) above the fifth wheel.

FIFTH WHEELS FOR LIGHT COMMERCIAL

Light Commercial	Type of Fifth Wheel	Stationary Fifth Wheel	Max. Rated Vertical Load Capacity	Max. Rated Gross Trailer Weight
Recreational Vehicle Trailer	Rigid	FW0001 ⁶	8,000 lbs. (3,630 kg.)	32,000 lbs. (14,500 kg.)
Light Duty Construction Trailer	Full-Oscillating	FW0002	8,000 lbs. (3,630 kg.)	32,000 lbs. (14,500 kg.)
Horse Trailer/Livestock	Semi-Oscillating	FW6000 ⁶	12,000 lbs. (5,440 kg.)	32,000 lbs. (14,500 kg.)
	Semi-Oscillating	FW1900	20,000 lbs. (9,070 kg.)	40,000 lbs. (18,140 kg.)





NOTE: Light commercial fifth wheels are specialty fifth wheels that do not fall within the application guidelines found on page 26. When specifying a light commercial fifth wheel, special attention must be given to both the drawbar pull (pulling capacity) and vertical load capacities of the fifth wheel.

⁶ Available in either inverted or standard mount.

POPULAR OPTIONS FOR FIFTH WHEELS

OPTIONS

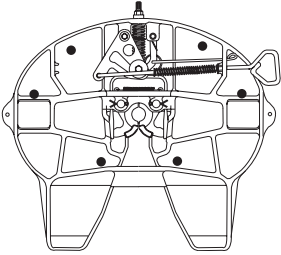
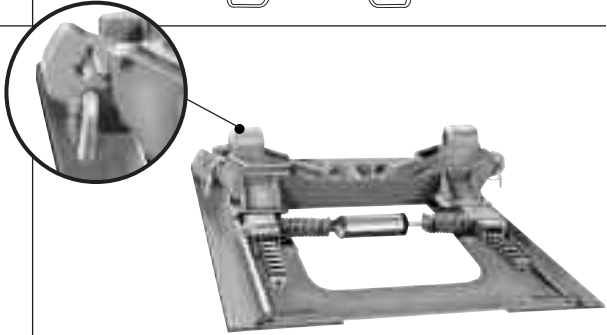
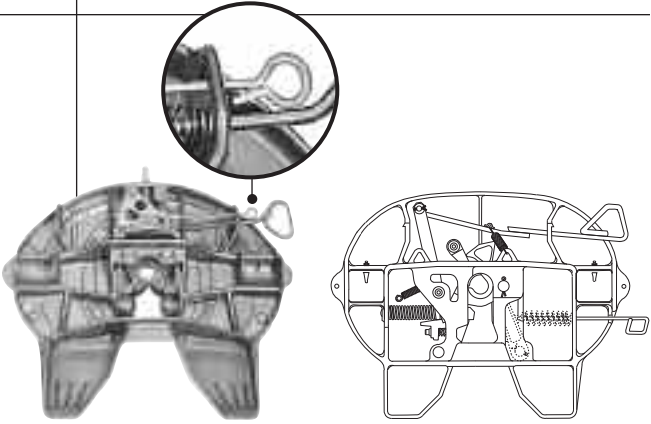
Description	Series / Notes	
<p>Air Release (Option Code 80 or 86) Permits the driver to quickly and safely control the uncoupling process from the cab.</p>	<p>Series: FW31 FW33 FW35 FW8 FW83</p>	
<p>(ELI®) Electronic Lock Indicator (Option Code ON) Allows the driver to successfully monitor and manage the coupling process from inside the cab.</p>	<p>Series: FW31 FW33 FW35 Yard Spotters (FW35 Series)</p> <p>Note: A visual inspection and a pull test are still required.</p>	
<p>Drilled and Tapped for Auto Lube (Option Code 24) Provides central point (manifold) of lubrication that distributed lubrication to all friction points between tractor and trailer.</p>	<p>Series: Most Models</p> <p>Note: Does not eliminate the need to routinely lubricate the fifth wheel lock mechanism. (See fifth wheel maintenance procedures for your model fifth wheel.)</p>	
<p>Kompensator® Lockouts (Option Code 19) Locks out the Kompensator feature to make the fifth wheel a semi-oscillating fifth wheel only.</p>	<p>Series: FW8 FW83 FW35 FW33 FW7040 FW7090</p> <p>Available for all Kompensator fifth wheel applications.</p>	
<p>Manual Secondary Lock (Option Code 2) An additional security lock that is manually disengaged and automatically engaged during coupling and uncoupling.</p>	<p>Series: FW35 FW33 FW31 FW8 FW83</p>	

Essential service and checking tools – specially designed for Holland products.

Fifth Wheel Lock Adjustment Tool

TF-TLN-5001

Designed specifically for the Holland FleetMaster top plate, but can be used with other Holland fifth wheels as well. Designed for checking fifth wheel locking action and lock adjustment during periodic adjustment or rebuilding.



3½" Fifth Wheel Lock Adjustment Tool

TF-TLN-1500

These Holland kingpin lock testers are designed for checking fifth wheel locking action and lock adjustment.



Slider Spring Compressor

TF-TLN-2500

Designed exclusively for removing and installing springs, retainers and pins of the slide release mechanisms of Holland sliding fifth wheels. For best results, operate with a 5/8" socket and ratchet wrench.



2" Plug

TF-0237

This 2" plug is used only for checking and adjusting the kingpin locks of the Type "B" fifth wheel during periodic maintenance. It also is designed to assist in lock installation and adjustment during rebuilding or lock replacement.



Fifth Wheel Rebuild Stand

TF-04229-1

The Holland fifth wheel rebuild stand allows top plate rotation for easy access to both bottom and top surfaces of the top plate for easy rebuilding. Easy nut and bolt assembly for convenience and compact storage.



FIFTH WHEEL LOCATION

A very important procedure, especially when using a stationary fifth wheel, is determining its location on the tractor. This is important to ensure proper load distribution and overall vehicle combination length. For proper vehicle steering stability, the fifth wheel centerline must be located forward of the rear axle on single axle tractors and forward of the bogie centerline on tandem axle trailers.

Step 1

Determine the maximum allowable kingpin load for the tractor, KP_{MAX}

$$KP_{MAX} = (\text{Tractor Axle Capacities}^*) - (\text{Tractor Curb Weight}^{**})$$

or

$$KP_{MAX} = (AF + AR) - (WF + WR)$$

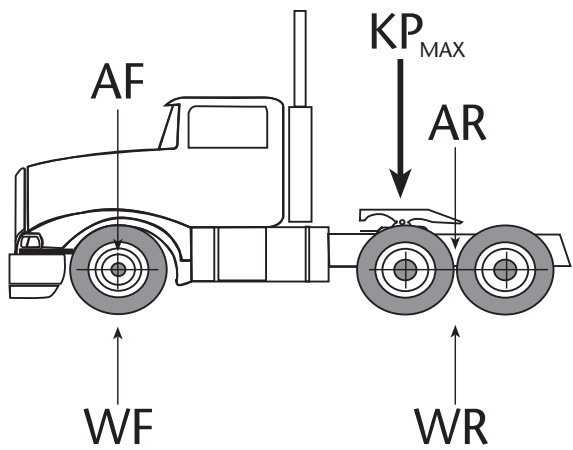

LEGEND

AF = GAWR tractor front axle*

AR = GAWR tractor rear axle*

WF = Tractor weight over front axle (curb**)

WR = Tractor weight over rear axle (curb **)

GAWR = Gross Axle Weight Rating

* This is the lesser value of the axle/tire/suspension ratings or the legal road weight limits.

** Road-ready curb weight, including all accessories (fifth wheel, fuel, and driver), but without trailer or payload.

IMPORTANT:

The fifth wheel should always be located forward of the rear axle or bogie centerline to ensure proper steering stability.

 Failure to properly locate the fifth wheel forward of the rear axle or bogie centerline can adversely affect steering stability potentially causing the driver to lose control of the vehicle.

WARNING

CORRECT

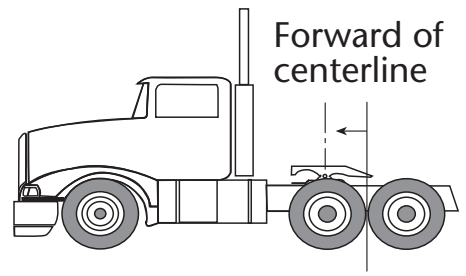

WRONG



The following procedure is offered as an aid in determining the optimum fifth wheel location for a particular application involving either a stationary or sliding fifth wheel.

FIFTH WHEEL LOCATION

Step 2

Determine the maximum forward fifth wheel location ahead of the rear axle or bogie centerline, D_{MAX}

(Maximum Allowable)

$$D_{MAX} = \frac{\text{Load Transfer to Front Axle} \times \text{Vehicle Wheelbase}}{\text{Maximum Kingpin Load}}$$

or

$$D_{MAX} = \frac{(AF - WF) \times WB}{KP_{MAX}}$$

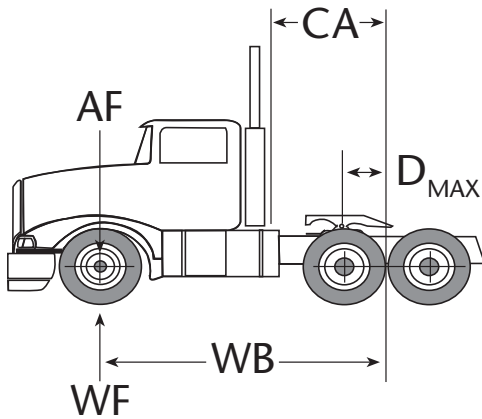

At this point, the fifth wheel can be positioned at any point between the bogie centerline and D_{MAX} depending upon the load distribution of the tractor. However, to insure proper swing clearance of the tractor and the landing gear, you must complete *Step 3*.

CHART A

Back of Cab Swing Clearance

Kingpin Setting ("KP")	CFW	
	Trailer Width ("W") 96"	102"
12"	53.5"	56.5"
18"	55.5"	58.5"
24"	58.0"	60.5"
30"	61.0"	63.5"
36"	64.0"	66.5"
42"	68.0"	70.0"
48"	72.0"	74.0"

$$D_{CFW} = C.A. - CFW$$

Step 3

Determine the required trailer swing clearances for:
(See illustration on page 46)

A. Cab to fifth wheel clearance, CFW.

Adequate swing clearance must be provided for the back of cab and landing gear. Using your trailer width (W) and kingpin setting (KP), select the required cab to fifth wheel clearance (CFW) from *Chart A*, below. Now, measure the distance from the back of the cab to the centerline of the rear axle or bogie, (C.A.). Next, subtract CFW from C.A. to obtain the maximum forward fifth wheel setting for cab clearance, D_{CFW} .

B. Landing gear to wheel clearance, LWC.

Adequate swing clearance must also be provided between the tractor tires and the trailer landing gear. First, measure the distance between the centerline of the kingpin and the centerline of the landing gear. Next, using *Chart B*, obtain the maximum forward fifth wheel setting for landing gear clearance, D_{LWC} .

CHART B

Landing Gear Swing Clearance

LWC		D_{LWC}
Distance from centerline of trailer kingpin to landing gear centerline (inches)		
Single Axle Tractor	Tandem Axle Tractor	Maximum fifth wheel setting ahead of rear axle or bogie centerline (inches)
55	71	
56	72	2
57	73	4
58	75	6
59	76	8
60	78	10
61	80	12
62	81	14
64	83	16
65	84	18
66	86	20
67	87	22
69	89	24
70	91	26
72	92	28
73	94	30
77	99	36
87	110	48

FIFTH WHEEL LOCATION

NOTE: The CFW dimension includes an additional 4" clearance for tractor and trailer articulation. Additional clearance may be required for items such as reefers, exhaust, stacks, glad hand racks, and headache racks. The LWC and D_{LWC} dimensions provide 3" of clearance between the landing gear and tractor tires assuming 10.00" x 20" tires. Subtract 1" from D_{LWC} for 22" tires.

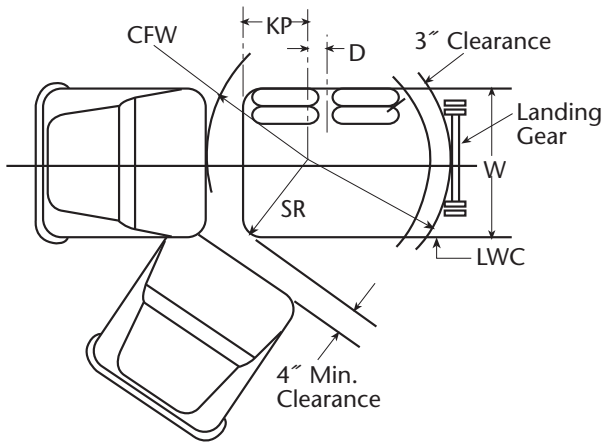

Step 4

Locate the Fifth Wheel

The maximum forward fifth wheel location, D_{MAX} , was determined in **Step 2** and based solely upon weight distribution. However, locating the fifth wheel at that position may not be possible because the vehicle may not have adequate swing clearance (as determined in **Step 3**). The fifth wheel should be located between D_{MAX} and the rear axle (bogie) centerline depending upon the application while still providing adequate swing clearance.

Proceed as follows:

- A.** Mark the maximum forward fifth wheel location D_{MAX} on the tractor frame.
- B.** Mark the D_{CFW} location on the tractor frame.
- C.** Mark the D_{LWC} location on the tractor frame.
- D.** Compare the markings. The fifth wheel should be located between the rear axle (bogie) centerline and the closer of D_{MAX} , D_{CFW} , or D_{LWC} . This will maintain adequate swing clearance (see figure below).

In the example below, the fifth wheel should be mounted between the centerline of the rear axle (bogie) and D_{CFW} since D_{CFW} must be maintained for cab to fifth wheel swing clearance.

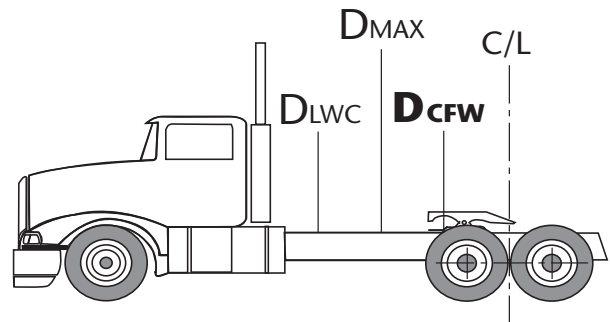

FIFTH WHEEL LOCATION

Example #1: Stationary Fifth Wheel

A 15,000 lbs. road-ready curb weight tractor has 8,000 lbs. on the front axle (WF) and 7,000 lbs. on the rear (WR). The front axle capacity is 12,000 lbs. (AF) while the rear tandem axle capacity (AR) is 34,000 lbs. The tractor has a 148" wheel base (WB) and an 80" C.A. The trailer is 102" wide with a 36" kingpin setting and landing gear wheel clearance (LWC) of 90".

STEP #1

$$\begin{aligned}
 KP_{MAX} &= (AF + AR) - (WF + WR) \\
 &= (12,000 + 34,000) - (8,000 + 7,000) \\
 &= (46,000) - (15,000) \\
 KP_{MAX} &= 31,000 \text{ lbs.}
 \end{aligned}$$

STEP #2

$$\begin{aligned}
 D_{MAX} &= \frac{(AF - WF) \times WB}{KP_{MAX}} = \frac{(12,000 - 8,000) \times 148}{31,000} \\
 D_{MAX} &= 19"
 \end{aligned}$$

STEP #3A

The required back of cab clearance, CFW, from **Chart A** (page 45) is 66½". The maximum fifth wheel setting ahead of the rear axle for cab clearance D_{CFW} is 13½", calculated as follows:

$$\begin{aligned}
 D_{CFW} &= (C.A. - CFW) \\
 D_{CFW} &= (80" - 66.5") \\
 D_{CFW} &= 13.5"
 \end{aligned}$$

STEP #3B

From **Chart B** (page 45), with a landing gear clearance of 90", the maximum fifth wheel setting ahead of the rear axle for landing gear clearance, D_{LWC} , is 25".

STEP #4

Mark D_{MAX} , D_{CFW} and D_{LWC} on the tractor frame and determine the fifth wheel location (see figure below).

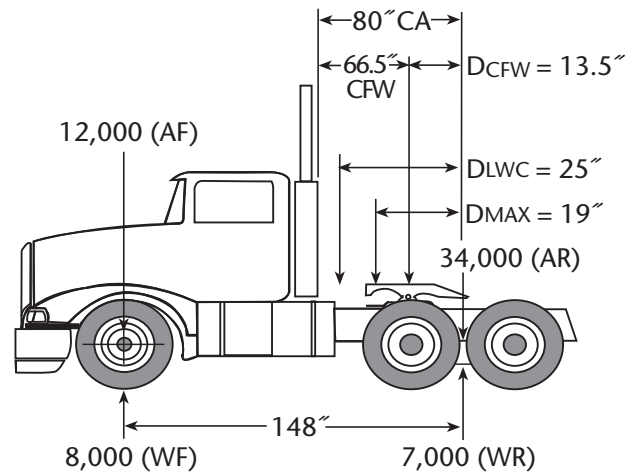

Result: In this example, the maximum fifth wheel setting ahead of the rear axle, D_{CFW} of 13.5" limits the fifth wheel location to a maximum of 13.5" ahead of the bogie centerline to allow for cab to trailer swing clearance. Therefore, the fifth wheel should be located between the centerline of the rear axle (bogie) and D_{CFW} . The expected trailer loads will help determine the ideal position of a stationary fifth wheel in this 13.5" range.

FIFTH WHEEL LOCATION

Example #2: Sliding Fifth Wheel

A 14,000 lbs. road-ready curb weight tractor has 8,000 lbs. on the front axle (WF) and 6,000 lbs. on the rear (WR). The front axle capacity is 13,500 lbs. (AF) while the rear tandem axle capacity (AR) is 34,000 lbs. The tractor has a 180" wheel base (WB) and a 92" C.A. The trailer is 102" wide with a 36" kingpin setting and landing gear wheel clearance (LWC) of 92". A sliding fifth wheel with 24.5" travel is recommended (from chart on page 49). What length sliding fifth wheel is recommended and where should it be positioned?

STEP #1

$$\begin{aligned}
 KP_{MAX} &= (AF + AR) - (WF + WR) \\
 &= (13,500 + 34,000) - (8,000 + 6,000) \\
 &= (47,500) - (14,000) \\
 KP_{MAX} &= 33,500 \text{ lbs.}
 \end{aligned}$$

STEP #2

$$\begin{aligned}
 D_{MAX} &= \frac{(AF - WF) \times WB}{KP_{MAX}} = \frac{(13,500 - 8,000) \times 180}{33,500} \\
 D_{MAX} &= 29.5"
 \end{aligned}$$

STEP #3A

The required back of cab clearance, CFW, from **Chart A** (page 45) is 66.5". The maximum fifth wheel setting ahead of the rear axle for cab clearance D_{CFW} is 13.5", calculated as follows:

$$\begin{aligned}
 D_{CFW} &= (C.A. - CFW) \\
 D_{CFW} &= (92" - 66.5") \\
 D_{CFW} &= 25.5"
 \end{aligned}$$

STEP #3B

From **Chart B** (page 45), with a landing gear clearance of 92", the maximum fifth wheel setting ahead of the rear axle for landing gear clearance, D_{LWC} , is 28".

STEP #4

Mark D_{MAX} , D_{CFW} and D_{LWC} on the tractor frame and determine the fifth wheel location (see figure below).

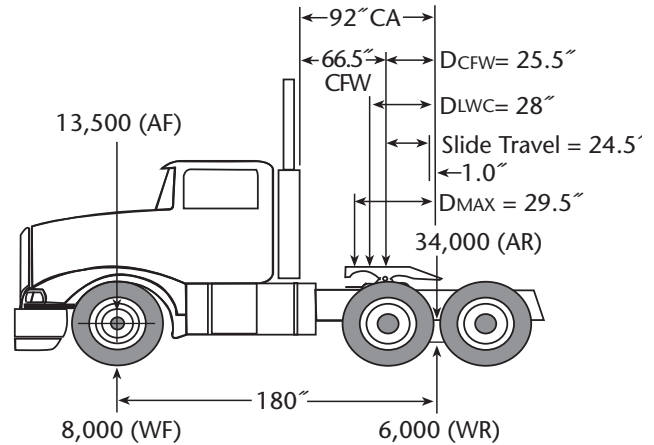

Result: In this example, the maximum fifth wheel setting ahead of the rear axle for trailer-to-cab clearance, D_{CFW} of 25.5" limits the fifth wheel location to a maximum of 25.5" ahead of the bogie centerline to allow for cab to trailer swing clearance when the fifth wheel is in the forward most position.

Using the slide travel tables on the following page to obtain a recommended style slide bracket, the use of a 16.5" slide bracket will provide us with 24.5" slide travel, but will not exceed the 25.5" maximum. A longer bracket can be used, and might be required depending upon the application, but the available slide travel will be reduced as indicated in the charts.

FIFTH WHEEL LOCATION

The following charts are offered as a guide to determine the maximum slide length to prevent tractor/trailer interference during cornering:



12.0" ILS Slide Bracket

Tractor C.A.	Max. Slide Travel*
79.5" – 91.5"	12.0"
91.5" – 103.5"	24.0"
103.5" – 115.5"	36.0"
115.5" – Above	48.0"

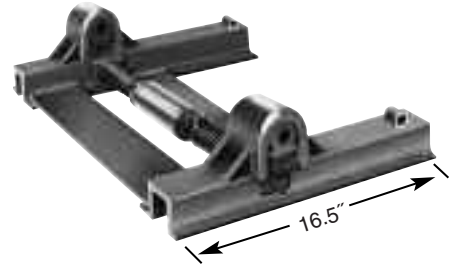

16.5" Slide Bracket

Tractor C.A.	Max. Slide Travel*
79.5" – 86"	12.2"
86" – 92"	18.4"
92" – 104"	24.5"
104" – 116"	36.7"
116" – 128"	48.9"
128" – 140"	61.2"
140" – Above	73.4"

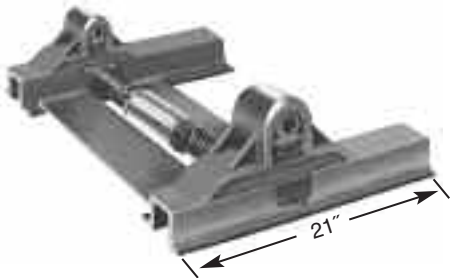

21" Slide Bracket

Tractor C.A.	Max. Slide Travel*
83.4" – 87.5"	13.8"
87.5" – 99.6"	19.9"
99.6" – 112"	32.1"
112" – 124.3"	44.4"
124.3" – 136.4"	56.6"
136.4" – Above	68.8"

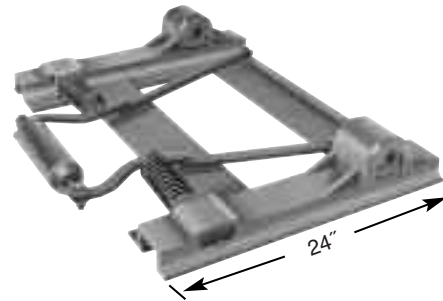

24" Slide Bracket

Tractor C.A.	Max. Slide Travel*
77.75" – 83.75"	10.7"
83.75" – 96"	16.8"
96" – 108"	24.5"
108" – 120.5"	41.3"
120.5" – 132.75"	53.6"
132.75" – Above	65.8"

* Based upon 36" kingpin setting and full-rear position of the fifth wheel 1" ahead of the rear suspension centerline. For other kingpin settings, add or subtract the difference in kingpin setting from C.A.

GLOSSARY

Articulation

Rotation about an axis. Generally referring to the fore/aft rotational movement between the fifth wheel and its mounting (See “Oscillation”).

A-Train

A combination of two or more trailers in which the dolly (converter or turntable) is connected by a single pintle hook or coupler, and the drawbar connection is at the center between each vehicle. The resulting connection has two pivot points (*Figure 1*).

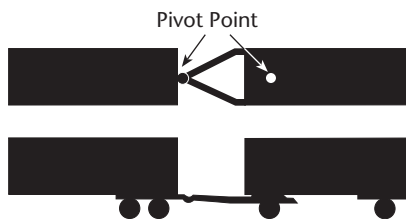

Figure 1

Air Operated Lock Release

The release mechanism for opening the lock mechanism of the fifth wheel. The driver sets the tractor parking brake to activate the system. The driver then pushes the air control valve to activate a pneumatic cylinder on the fifth wheel to open the locks.

Air Slide Release

The release mechanism for a sliding fifth wheel which is operated from the cab of a tractor by actuating an air control valve. When actuated, the valve energizes an air cylinder, which releases the slide lock and permits re-positioning of the fifth wheel.

Articulating Upper Coupler

A bolster plate - kingpin arrangement that is not rigidly attached to the trailer, but provides articulation and/or oscillation (e.g. frameless dump) about an axis parallel to the rear axle of the trailer.

Axles, Numbering

When used in this guide to select a fifth wheel, the number of axles (for example, “Up to 4-axle trains”) refers to the total number of axles on the “towed vehicle(s)” or trailer(s). It does not include the axles on the towing vehicle.

B-Dolly Train

A combination of two or more trailers in which the dolly (converter or turntable) is connected by two or more pintle hooks, couplers and drawbar connections located between each vehicle, thus making a rigid connection (*Figure 2*). The resulting connection has one pivot point.

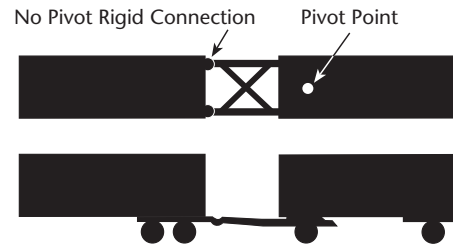

Figure 2

B-Train

A combination of two or more trailers in which the rear semi-trailer(s) is connected with a single pivot point, commonly a fifth wheel, mounted on an extension of the frame of the lead trailer (*Figure 3*).

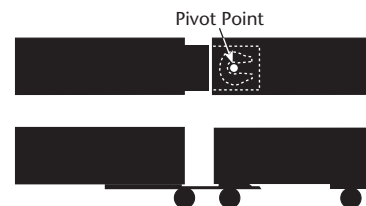

Figure 3

Bogie

The axle spring, suspension arrangement on the rear of a tandem axle tractor.

Bolster Plate

The flat, load-bearing surface under the front of a semi-trailer, including the kingpin, which rests firmly upon the fifth wheel when coupled. The bolster plate is sometimes referred to as an upper coupler.

Bolster Plate Height

The height from the ground to the bolster plate when the trailer is level and unlade.

c.g.

Abbreviation for center-of-gravity. Used in this guide to mean the center-of-gravity of the loaded trailer.

C-Train

A combination of two or more trailers in which the dolly (converter or turntable) is connected to the trailer by means of two pintle hook or coupler-drawbar connections. The resulting connection has one pivot point. (See also “B-Dolly Train”)

Center-of-Gravity (c.g.)

That point in a vehicle or body where the total weight or mass could be considered to be concentrated. Used in conjunction with vehicle stability and weight distribution on its axles.

City Pick-up and Delivery

Pick-up and delivery service within cities and/or suburban areas with typical distance between starts and stops of 3 miles or less.

Converter Dolly

An axle, frame, drawbar and fifth wheel arrangement that converts a semi-trailer into a full trailer.

Drawbar Capacity

The maximum, horizontal pulling force that can be safely applied to a coupling device.

Electronic Lock Indicator (ELI®)

Electronic monitoring and data collection system that monitors the coupling process from inside the cab. Magnetic proximity sensors located on the fifth wheel top plate senses fifth wheel and kingpin locking sequence, relaying the data to the driver through an icon based display in the cab.

Extra Capacity

Generally refers to a coupling device which has strength capability greater than standard.

Fifth Wheel Height

The distance from the ground to the top of the fifth wheel when it is level and parallel with the ground. It can also refer to the height from the tractor frame to the top of the fifth wheel. The latter definition applies to data given in fifth wheel literature.

Fifth Wheel Top Plate

The portion of the fifth wheel assembly that contacts the trailer bolster plate and houses the locking mechanism that connects to the kingpin.

Frame Width

The measurement across the outside of the frame rails of a tractor, truck or trailer. (See *Figure 4*)

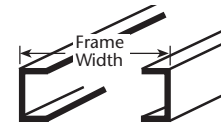

Figure 4

Full Trailer

A trailer which does not transfer load to the towing vehicle. It employs a towbar coupled to a swiveling or steerable running gear assembly at the front of the trailer.

Fully Oscillating Fifth Wheel

Generally refers to a fifth wheel type with fore/aft and side-to-side articulation. (See “Oscillation”)

G.T.W. – Gross Trailer Weight or Gross Towed Weight

The sum of the weight of an empty trailer(s) and its payload.

General Over-the-Road Use

When used in this guide means, a fifth wheel that is designed for multiple standard duty highway applications.

ISL

Integrated Low Weight Slider

Inboard Angle Mount

The horizontal leg of the mounting angle sits on the tractor frame.

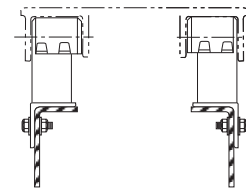

Kingpin

The pin mounted through the center of the trailer upper coupler (bolster plate) that mates with the fifth wheel locks securing the trailer to the fifth wheel. The configuration is controlled by industry standards. See SAE J700 and SAE J848.

GLOSSARY

Kompensator® Fifth Wheel

A fifth wheel designed to relieve some of the torque and twist that is generated by some trailer designs, thereby reducing or eliminating trailer frame cracks. Tractor tandem tire life is also greatly increased due to improved traction. The primary application for this fifth wheel is for tankers in which the c.g. does not exceed 44 inches above the top surface of the fifth wheel.

LowLube

A fifth wheel with recesses cast into the top plate into which lube free inserts are attached to eliminate the use of top plate grease. Also includes lube free inserts between top plate and brackets to eliminate lubrication and a grease fitting which permits periodic greasing of the locks.

Manual Slide Release

The release mechanism for a sliding fifth wheel which is operated by hand.

Mounting Bracket

That portion of the fifth wheel assembly that connects the fifth wheel top plate to the tractor frame or fifth wheel mounting system.

No-Tilt Convertible Fifth Wheel

A fifth wheel that has fore/aft articulation which can be locked out to produce a rigid top plate for applications that have either rigid and/or articulating upper couplers.

NoLube

A fifth wheel with recesses cast into the top plate into which lube free inserts are attached to eliminate the use of top plate grease. The entire locking system is treated with special coatings that eliminate grease requirements. Also includes lube free inserts between the top plate and brackets to eliminate lubrication in the bracket pocket area.

Off-Road

Refers to the terrain on which a tractor-trailer will operate which is unpaved and rough, or ungraded. Any terrain not considered part of the public highway system falls under this heading.

On-Road

Refers to the terrain on which a tractor-trailer will operate which is paved or a smooth graded surface, generally considered to be part of the public highway system.

Oscillation

Rotational movement in either fore/aft or side-to-side direction about a pivot point. Generally refers to fifth wheel designs in which fore/aft and side-to-side articulation are provided.

Outboard Angle Mount

The horizontal leg of the mounting angle faces outward.

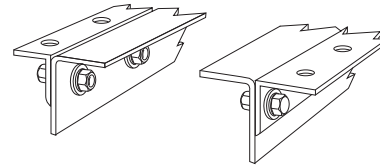

Over-the-Road

Used interchangeably with on-road. See “On-Road” below in left column.

Rated Capacity

The maximum, recommended safe load that can be sustained by a component or assembly without permanent damage.

Rigid Fifth Wheel

A fifth wheel that is fixed rigidly to a frame. This fifth wheel has no articulation or oscillation. Generally used in applications where the articulation is provided by other means, e.g., an articulating upper coupler of a frameless dump.

Roll Axis

The theoretical line that joins the roll center of the front and rear axles.

Roll Center

The instant (always changing) center about which the vehicle sprung mass rotates when lateral (rollover) forces are applied. Generally this is located at the fore/aft center of the suspension at a height where the springs attach to the frame links (*Figure 5*).

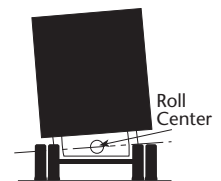

Figure 5

Secondary Lock

Refers to a component or components of a fifth wheel locking mechanism that may be included as a back-up system for the primary locks. The secondary lock is not required for the fifth wheel to function and can be either manually or automatically applied. On some designs, the engagement of the secondary lock can only be accomplished if the primary lock is properly engaged.

Semi-Oscillating

Generally refers to a fifth wheel type which oscillates or articulates about an axis perpendicular to the vehicle centerline. (See description on Page 6).

Semi-Trailer

A load carrying vehicle equipped with one or more axles and constructed so that its front end is supported on the fifth wheel of the truck tractor which pulls it.

Sliding Fifth Wheel

A specialized fifth wheel design which incorporates provisions to readily relocate the kingpin center forward and rearward affecting the weight distribution on the tractor axles and/or overall length of the tractor and trailer.

Slide Travel

The distance that a sliding fifth wheel is designed to move.

Stability

A relative measure of the handling characteristics which provide the desired and safe operation of the vehicle during various maneuvers.

Stationary Fifth Wheel

A fifth wheel whose location on the tractor frame is fixed once it is installed.

Tilt Stop

A block or formed plate welded to a fifth wheel mounting bracket that limits the rearward articulation of the fifth wheel. Tilt stops are often used to keep the fifth wheel from resting on or damaging the tractor frame rails.

TTMA

Truck Trailer Manufacturers Association
1020 Princess Street, Alexandria, VA 22314-2247
Phone: (703) 549-3010 Fax: (703) 549-3014

tw (Towed Vehicle Weight)

Total weight of towed vehicles.

Torque & Twist

Generally refers to the forces developed in the trailer and/or tractor frame that are transmitted through the fifth wheel when a rigid trailer (e.g. a tanker) is required to negotiate bumps (i.e. street curbs, etc.).

Torsional Rigidity

A component's ability to remain rigid when subjected to twisting forces.

Universal Fifth Wheel

(See "Fully Oscillating Fifth Wheel")

Upper Coupler

(See "Bolster Plate")

Vertical Load Capacity

The maximum, recommended vertical force (down) than can be safely applied to a coupling device.

For more information, please visit our website at www.thehollandgroupinc.com or contact your local Holland representative at 888-396-6501 or e-mail us at fifthwheel@thehollandgroupinc.com.



From rebuilding your fifth wheel to servicing your suspension, Holland's Genuine Parts are the same quality components designed, tested and built for the original assembly. Holland Genuine Parts provide the performance, durability and reliability you have come to expect from your Holland product. Will-fits, look-alikes and counterfeit parts will only limit performance potential and possibly void Holland's warranty. Always be sure to spec Holland Genuine Parts when servicing your Holland product.

Never Compromise! Demand Holland Genuine Parts.



HOLLAND USA, INC.

1950 Industrial Blvd. P.O. Box 425
Muskegon, MI 49443-0425
Phone 888-396-6501 Fax 800-356-3929

HOLLAND HITCH OF CANADA, LTD.

Woodstock, Ontario, Canada
Phone 519-537-3494 Fax 800-565-7753
Surrey, British Columbia, Canada
Phone 604-574-7491 Fax 604-574-0244

HOLLAND INTERNATIONAL, INC.

Holland, MI 49423
Phone 616-396-6501 Fax 616-396-1511

Copyright © December 2006 • The Holland Group, Inc.



GO THE DISTANCE.

www.thehollandgroupinc.com