

Hook-All™ HookLIFTS

BY AMERICAN ROLL-OFF®



HAD-250-140-54 25,000 lb Capacity for 14 and 16 ft containers
HAD-300-140-61 30,000 lb Capacity for 14 and 16 ft containers

Hook-all Hooklifts are designed to lift, dump and load a variety of bodies allowing you to increase your truck utilization.

Product features:

Designed for 14 ft and 16 ft containers

High Dump, “True Dump Truck” style dumping, Dual Pivot

Designed and Manufactured in the United States

**Low pressure 2800 PSI hydraulics easily adapts to
hydraulic based accessories.**

Dual lift pistons

**Sliding jib to accommodate short containers and adjust
the weight distribution**

Dual rear rollers and side rollers for easy container movement

Poly fenders with full width bumper

LED stop, turn and marker lights with factory plug in harness

Pintle Hook mounting plate is standard

**Patented Floating Jib eliminates all electromechanical controls
and allows the body to be slid back during the dump mode**

US Manufactured pump, valve, cylinders and fittings

**All models include an A-Frame drawing so you can manufacture
your own bodies.**

HAD-250-140-54 25,000 lb Capacity for 14 and 16 ft containers

HAD-300-140-61 30,000 lb Capacity for 14 and 16 ft containers

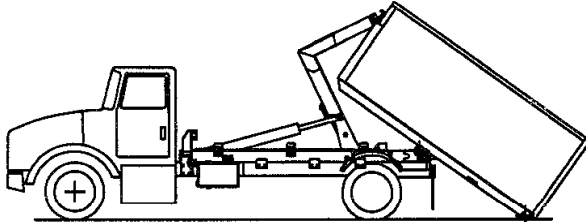
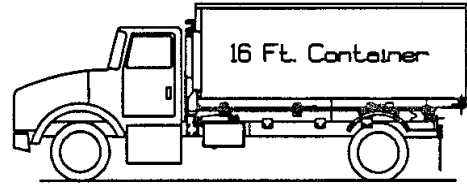
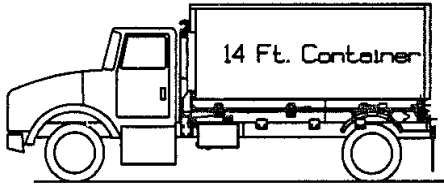

Max. Loading Angle 35 Deg.

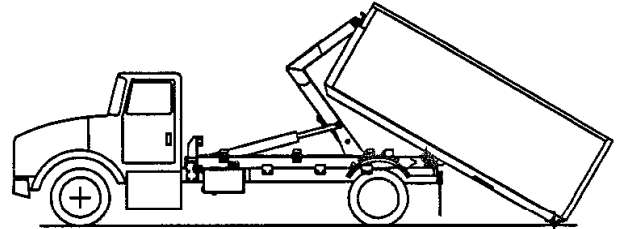

Max. Loading Angle 30 Deg.

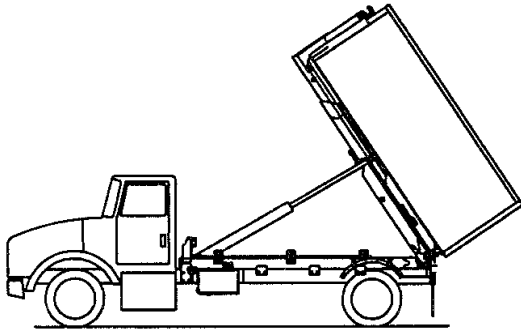

Max. Dumping Angle 56 Deg.

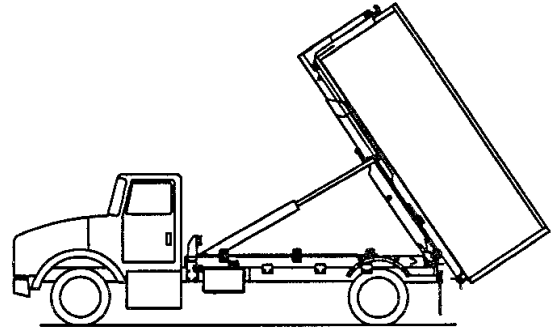

Max. Dumping Angle 56 Deg.

Customized quick change bodies we have manufactured and supplied include:

**Open Top Containers
Closed Storage Bodies
Salt and Sand Spreaders
Tree spraying units
Septic Cleaning Pumps
Hydroseeders
Concrete Forms
Scaffold delivery skids**

**Recycling containers
Flatbed Bodies
Dump bodies: standard & heated
Water tanks & spraying systems
Liftgate bodies
Cranes: skid mounted
Bark Mulch Blowers
Contractors Bodies**

Hook-All[®] Hooklifts are produced in the United States by the manufacturer of the American Roll-off[®] with over 35 years experience in quick change bodies.

Manufactured Exclusively by:

Automated Waste Equipment Co.

PO BOX 5757, 3 Tennis Court, Trenton, NJ 08638

Phone: 609-588-5400 Fax: 609-588-4104

www.americanrolloff.com

Copyright Automated Waste 2007 Rev 11-07

Distributed By: