

VARIED CAPACITIES

INCREASED DURABILITY

H COMPOSILITE™ ST Lightweight PARALIFT ULTRA™

COMPOSILITE™ ST — the ultimate system for weight-conscious haulers looking for quality, lightweight products. This low-maintenance, compact self-steering suspension is available in 9,000- and 13,500-pound capacities in truck and trailer configurations.

Reduced Maintenance

- Bronze bushings and two-piece knuckle design provide extended kingpin performance
- In-line air springs provide more protection from road debris
- Enclosed stabilizer protects rod throughout travel

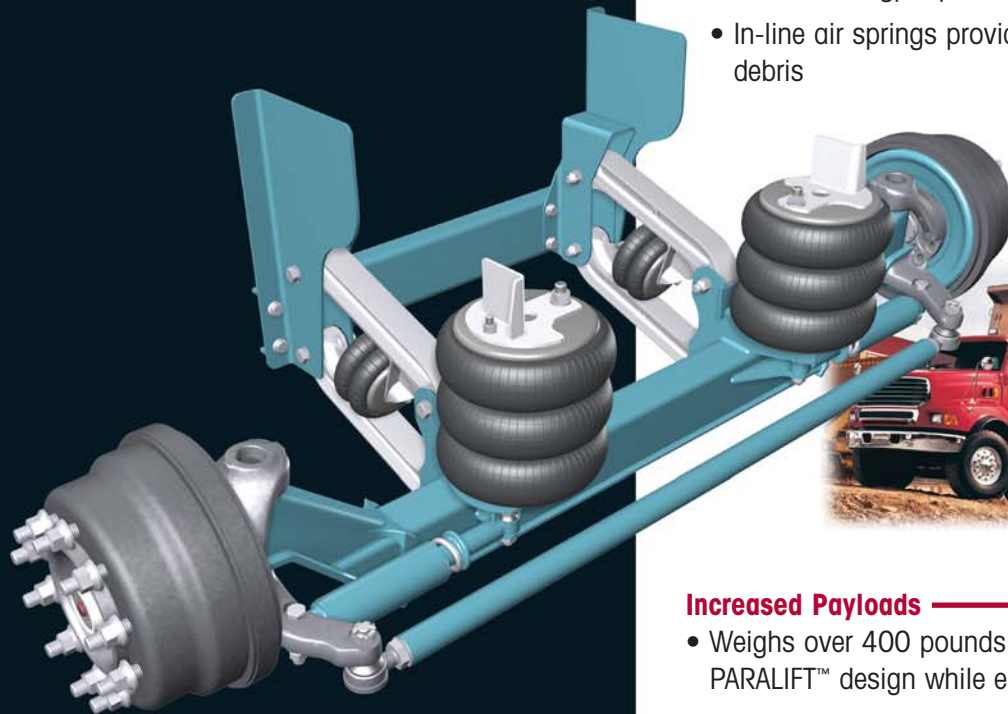

Increased Payloads

- Weighs over 400 pounds less than the original PARALIFT™ design while enhancing durability
- Tight 23.5-inch package space allows easier multi-axle configurations
- Choice of capacities to meet your needs

Improved Performance

- Zero-torsion bushings help eliminate bushing windup and provide smaller package space for lightweight product
- Improved wheel cut provides additional installation flexibility

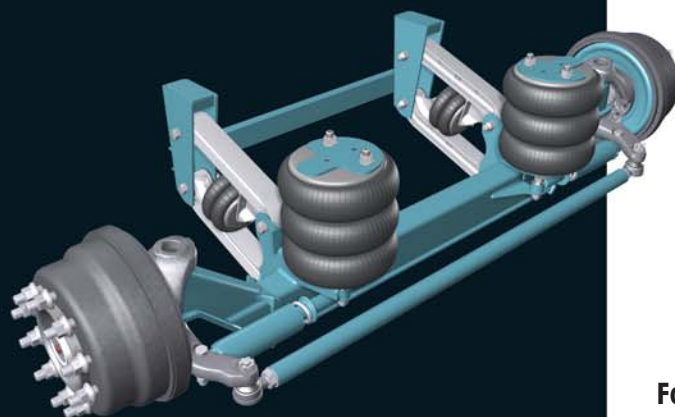

For more information, please call 1-800-660-2829 or visit www.hendrickson-intl.com

For The Road Ahead™

H HENDRICKSON

COMPOSILITE™ ST Specifications

	Truck		Trailer	
Suspension Capacities	9,000 lbs.*	13,500 lbs.	9,000 lbs.	13,500 lbs.
Weight	720 lbs.	788 lbs.	725 lbs.	766 lbs.
Axle Type	Self-steering, in-line kingpin			
Application	Pusher or tag position			
Total Axle Travel	13.5 inches with 10 inches of lift			
Packaging Space	23.5 inches from front edge of hanger to centerline of axle			
Wheel Cut	28 degrees			
Brakes	15- x 4-inch S-cam			

* 9,000-pound capacity suspension available with aluminum or steel hangers

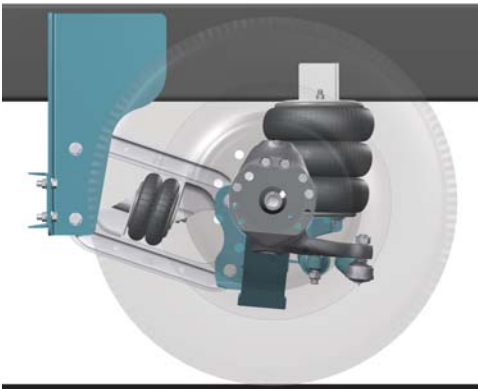

*COMPOSILITE™ ST with 22.5-inch wheel
13,500-pound capacity*

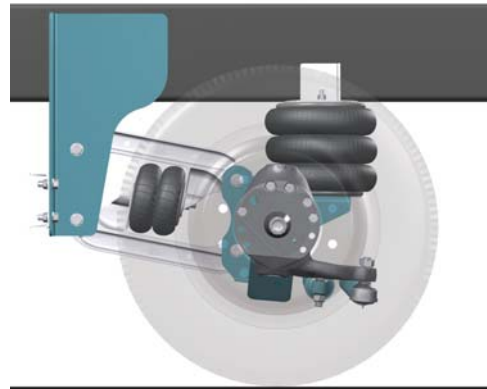

*COMPOSILITE ST with 19.5-inch wheel
9,000-pound capacity*

Truck Suspension Weight Comparison

Suspension Capacity	Suspension Weight	Tire / Rims		Total Weight
		Type	Weight**	
13,500 lbs.	788 lbs.	11R22.5	351 lbs.	1,139 lbs.
		255 70R22.5	300 lbs.	1,088 lbs.
9,000 lbs.	720 lbs.	265 70R19.5	243 lbs.	963 lbs.
		245 70R19.5	231 lbs.	951 lbs.
		225 70R19.5	210 lbs.	930 lbs.

** Typical weight used, check with manufacturer for exact weight

For further information and application specifications, call 800-660-2829 in the United States or 800-668-5360 in Canada.



Information contained in this literature was accurate at the time of publication. Product changes may have been made after the copyright date that are not reflected.

Auxiliary Axle Systems
277 North High Street
Hebron, OH 43025

740.929.5600
Fax 740.929.5601

www.hendrickson-intl.com