

Anthony **LoadBlazer**TM

Hydraulic Liftgates[®]



A New Dimension in Pickup Liftgates

- **Direct Drive Twin Cylinder Power**
- **Heavy Duty Stabilizer Beam**
- **1,500 lb. Lifting Capacity**
- **Large Platform**
50" x 41" + 6"
- **Bed Height up to 46"**



Prepped with
Steel Shot Process



(See page 3)

ANTHONY
LIFTGATES, INC.[®]

LoadBlazer — A Commercial Grade Pickup Truck Liftgate.

Anthony: Industry Leader

Anthony Liftgates Inc. has been the driving force in the trucking industry since 1941, offering innovative designs and quality liftgates for trucks of all sizes. Anthony's LoadBlazer delivers performance, dependability, and value.

LoadBlazer™

A unique **Stabilizer Beam** — a beefy 3 inch, 11 gauge tubular steel beam connects two lift arms, balancing heavy loads and virtually eliminating side to side shifting.

Twin Hydraulic Cylinders provide direct drive lifting power, evenly, at each side.

No lifting cables or chains to maintain and wear out.

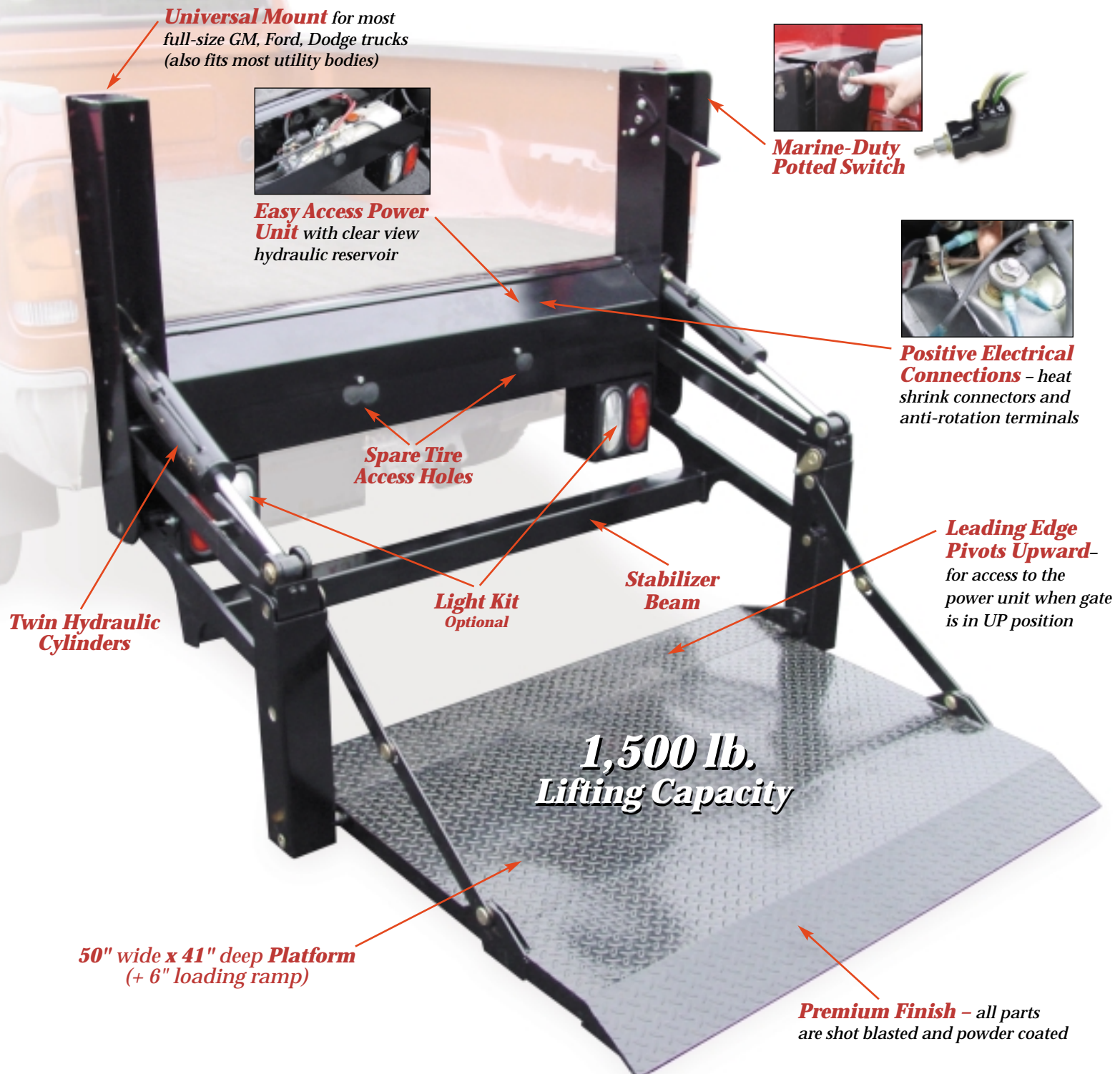

Quality Standard Features for Pickup Liftgate Performance.

Heavy Duty Capacity – 1,500 pound lifting capability with unique stabilizer beam.

Fits Full-Sized Pickups – The LoadBlazer is engineered for most full size GM, Ford, or Dodge pickups; also fits most utility bodies.

Large Platform & Opening – Full 50" wide x 41" deep platform (+ 6" loading ramp) with 52 1/2" opening into truck bed. Bed height travel up to 46". Two piece treadplate folds even with sides of truck bed in closed position for normal rear visibility.

Twin Cylinders – Built for commercial liftgate applications: dual wear rings, long piston and rod glands, double-lip piston and rod seals, thick-lip rod wiper, low-pressure buffer seal, body tube honed to a super-smooth surface, piston rod chrome plating twice as thick (.001 per side) compared to industry standard. The result is dependable, long-life service.

Service Free – Composite bushings are used at all major pivot points

Zero Leak – Machined fittings, "O" rings, and JIC hydraulic connections, along with factory installed -70° low pour hydraulic fluid result in long, trouble-free service with no aggravating leaks.

Marine-Duty Potted Switch – Terminals & wire connections are encapsulated in a field of epoxy for permanent insulation and corrosion protection. (flush mounted)

Easy Access Power Unit – Accessible through a steel panel on top of rear bumper housing. Clear-view hydraulic reservoir provides quick fluid level inspection.

Flow Valves – Pressure compensated, prevent free-fall in the event of certain hydraulic failures.

Circuit Protection – Safeguards truck wiring and power system in the event of a "dead short."

Relief Valve – Prevents overloading during lift cycle.

Positive Electrical Connections – Heat-shrink siliconed wire connectors seal out moisture to prevent electrical failure, and anti-rotation terminals insure circuit protection.

Plated Pins – Yellow Di-Chromated plated corrosion-resistant pins stop rust and weather damage

Low Operating Pressure – Extends service life of power unit, hoses, cylinder seals, and battery.

Sealed Hydraulic System – Provides positive protection from outside dust, dirt, and moisture.

Factory Assembled – Tested, and Energized – Ensures reliability and prevents contamination of hydraulic system which may occur during field installation.

E-Z Mount Installation – Ships completely assembled for fast, clean, easy installation.

Spare Tire Access – Accessible through two holes in rear frame.

Towing – Designed to allow clearance for use of most trailer hitch assemblies.

Premium Finish – The best-looking liftgate in the industry – all parts are shot-blasted, then the entire liftgate is powder coated to a premium gloss black finish. An aluminum appearance plate covers the platform bolsters and provides a smooth, clean, truck OEM look.



Exclusive 2+1 Warranty – 2 years on mechanical parts, 1 year on hydraulic system.

* NOTICE: Some models of Anthony Liftgates may be provided with step devices to assist the ingress and egress of the truck or trailer rear. These devices are NOT to be considered ALL INCLUSIVE of any requirements or guidelines regarding proper ingress and egress of trucks and trailers. These items are provided as only an added feature for installers to help simplify the meeting of possible ingress and egress requirements. As there are many variables in truck sizes and shapes, it is the installer's responsibility to determine proper ingress and egress requirements, such as steps and hand grips, for each vehicle receiving an Anthony liftgate.

Available Models, Platforms and Capacities

MODEL	Lifting Capacity (lbs.)	Bed Height Min-Max	Platform Load Area and Ramp	Shipping Wt. (lbs.)
ALB-1500SF	1,500	Up to 46"	50" x 41" + 6" ramp	450
ALB-1500A-SF	1,500	Up to 46"	50" x 41" + 6" ramp	423

Specifications subject to change without notice.

Life Cycle Testing

In a comprehensive endurance test, we cycled the LoadBlazer over 100,000 times in a continuous run with a 1,530 lb. payload, in both the up-and-down mode. This translates into 200,000+ actual duty cycles - over 40 cycles a day for 20 years! During this entire test, there were **no signs of wear** to any of our *Service-Free* composite bushings or to any of the pivot pins. No grease or other lubricant was used on any of the pivot wear points.



Service-Free™ Bushings

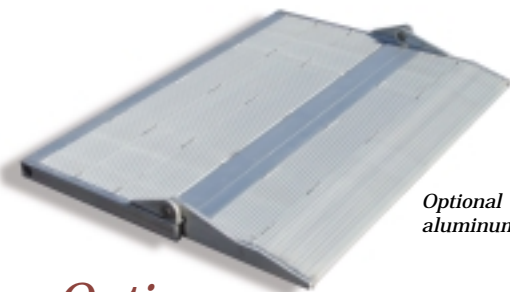
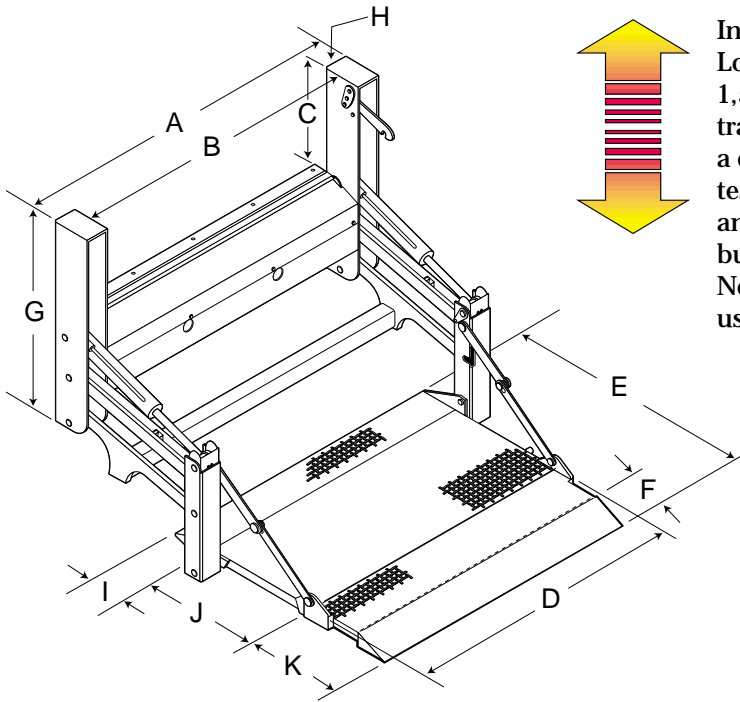

Optional aluminum platform

Options:

- Cab cut-off switch (recommended)
- Aluminum platform
- Light Kit - designed to meet federal/state/local regulations, depending on installation

LoadBlazer Dimensions

A	B	C	D	E	F	G	H	I	J	K
61.7"	52.5"	19.5"	50"	46.0"	5.0"	36.75"	4.6"	7.3"	21.8"	16.9"



LoadBlazer delivers the quality and durability you need for every liftgate application, plus the good looks to compliment your truck.

ANTHONY LIFTGATES, INC.®

Anthony Liftgates, Inc.
 1037 W. Howard Street
 P.O. Box 615
 Pontiac, IL 61764-0615
 Phone: 815.842.3383
 Fax: 815.844.3612
 Toll Free: 800.482.0003
 www.anthonyliftgates.com