

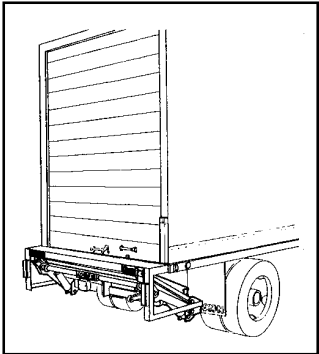

SPECIFICATIONS

MODELS: GPT-25, GPT-3, GPT-4 GPT-5

TUK-A-WAY LIFTGATES
Wide Arm, Leveling Ride,
Large Platform, High Capacity



All **TUK-A-WAY** liftgates have platforms that fold and stow under the body in the dock-ready position.

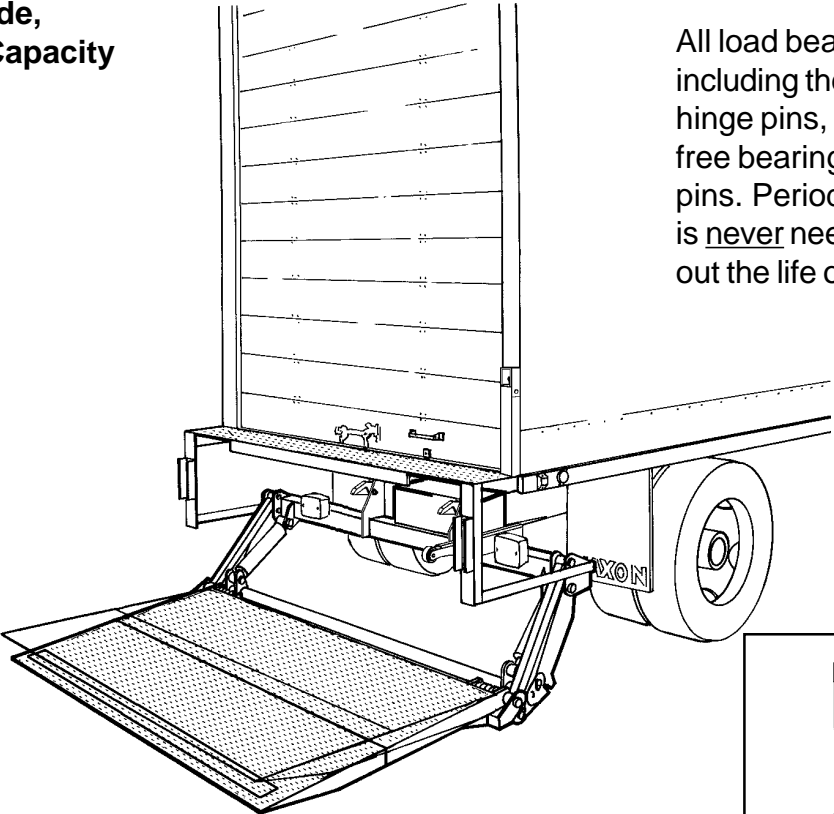

All load bearing pins, including the platform hinge pins, use grease free bearings and plated pins. Periodic greasing is never needed throughout the life of the liftgate.

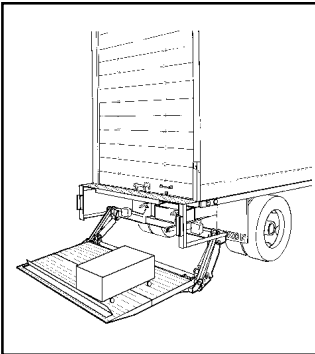

Recommended for general, specialized and pallet loading with combination dock and street delivery. Ideal with optional Single or Dual Cart Stops* to secure wheeled loads during operation. Cart Stop retracts into platform when not in use.

MODEL (CAPACITY)	60" X 80" PLATFORM (OVERALL WEIGHT)	BED HEIGHT	<p>(Platform Area used by Cart Stop option) 20" GPT-25, GPT-3 24" GPT-4, GPT-5</p> <p>14"</p> <p>BED HEIGHT</p> <p>10"-19" GPT-25, GPT-3 12"-21" GPT-4, GPT-5</p> <p>MOUNTING REQUIREMENT DIMENSIONS</p>
GPT-25 (2500 LBS.)	(1115 LBS.)	46" Laden 55" Unladen	
GPT-3 (3000 LBS.)	(1115 LBS.)		
GPT-4 (4000 LBS.)	(1140 LBS.)	46" Laden 55" Unladen	
GPT-5 (5000 LBS.)	(1140 LBS.)		

* NOTE: Cart Stops reduce the useable platform area in depth by 12" when activated.

SPECIFICATIONS

MODELS: GPT-25, GPT-3, GPT-4 GPT-5

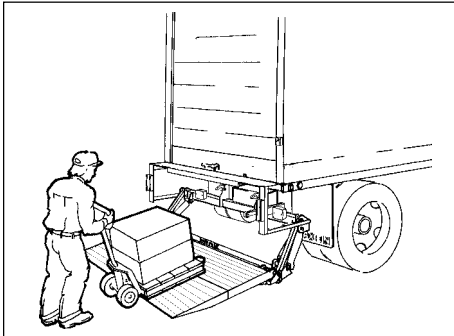

RAMPS TO GROUND

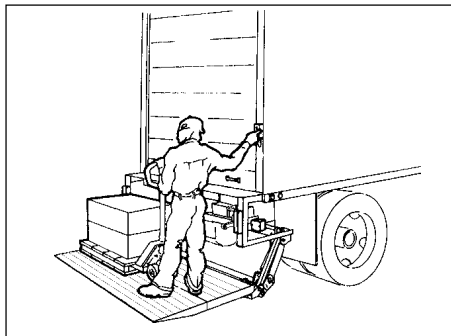

PIVOTS TO LEVEL

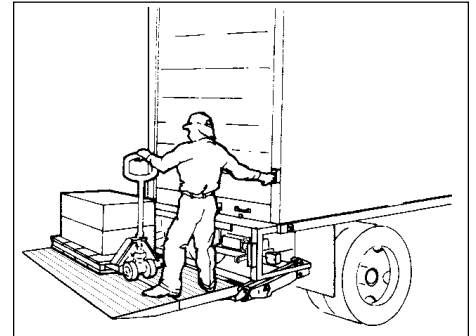

LEVEL RIDE

The patented "leveling joint" on each lift arm gives the GPT models a unique ability. In the raising cycle the entire platform pivots up to the level position and remains level as it continues to bed height. When the platform is lowered, it stays level until the lift arms make ground contact. Then, the operator can pivot the platform down to the ramp position to unload cargo. The operator has complete control of the ramping and leveling of the platform, using the toggle switch controls.

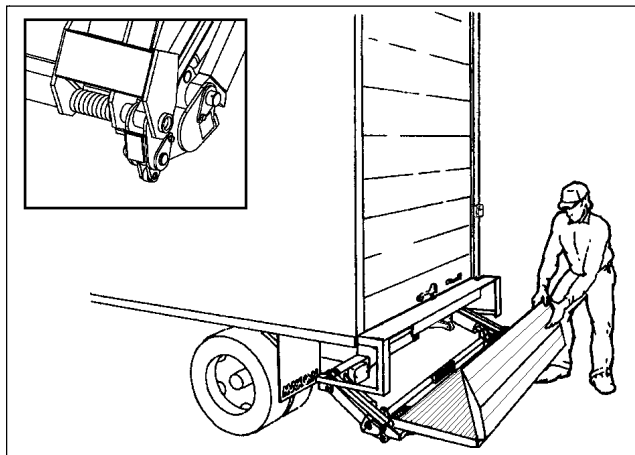

ALL ALUMINUM PLATFORM

The GPT design uses a light-weight, rust proof extruded aluminum platform, allowing for large platforms up to 60" for increased load area, without the higher weight of older steel designs.

Powerful dual platform torsion springs make the large platform easy to handle by reducing the effort required for opening and closing.

STANDARD EQUIPMENT

- Extruded All Aluminum Platform
- Heavy Duty Dock Bumpers
- Dock Bumper Rubber Pads
- Toggle Switch Control (Sealed Marine)
- Power Down
- Steel Pump & Motor Enclosure
- Grease Free Bearings

Distributed By:

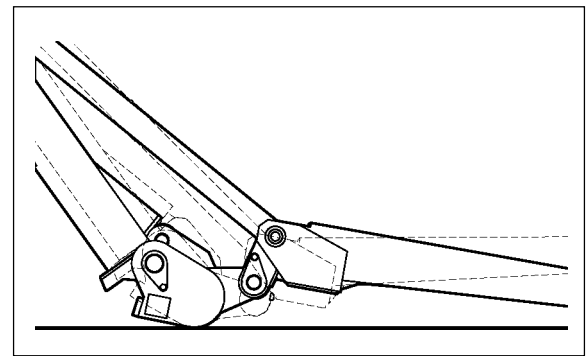

LEVELING JOINT

The GPT "leveling joint" is a breakthrough in simplicity in the design of heavy-duty, **TUK-A-WAY** liftgates. It eliminates the need for the complex and exotic multi-function hydraulic system required to level large platforms during the lifting and lowering cycles.

OPTIONAL EQUIPMENT

- Cab Cut Off Switch
- Single Low Voltage Thermal Switch (LVTS)
- Dual Switch Control
- Underide
- Liftgate Bumper
- Frameless Trailer Subframe Mounting
- 102" Wide Trailer Kit
- 2-Step Dock Bumper
- 150 Amp Circuit Breaker (No Charge Option)
- Hand Held Control
- Street Side Control
- Recessed Cart Stop (Reduces Platform area by 12" in depth when activated.)
 - Single
 - Dual

M-103-0304

MAXON LIFT CORP. 11921 Slauson Ave., Santa Fe Springs, CA. 90670-2221
(800) 227-4116, FAX: (888) 771-7713, www.maxonlift.com